

MODEL EST44 PARTS MANUAL

Rev.2.02A



CMA DISHMACHINES
12700 KNOTT STREET
GARDEN GROVE
CALIFORNIA 92841

800-854-6417
FAX 714-895-2141



Table of Contents

EST-44

- 1. PARTS MANUAL..... 4**
 - 1.1. Initial Parts Kit 4
 - 1.2. Exploded View Drawings..... 5
 - 1.2.1. Cabinet Assembly 5
 - 1.2.2. Control Box Assembly 6
 - 1.2.3. Curtain and Optional Vent System 7
 - 1.2.4. Old Wash Temperature Control System (Square Flange) 8
 - 1.2.5. New Wash Temperature Control System (Triangular Flange)..... 9
 - 1.2.6. Rinse Temperature Control System 10
 - 1.2.7. Wash Pump Assembly 11
 - 1.2.8. Rinse Pump Assembly..... 12
 - 1.2.9. Drain System Assembly..... 13
 - 1.2.10. Plumbing System Assembly (Auto-Fill) 14
 - 1.2.11. Plumbing System Assembly (Final Rinse)..... 15
 - 1.2.12. Wash System Assembly 16
 - 1.2.13. Rocker Arm Assembly..... 17
 - 1.2.14. Start Switch and Rinse Switch Assembly 18
 - 1.2.15. Optional E-Temp Heater 19
- 2. TABLE LIMIT SWITCH INSTRUCTIONS (P/N 13469.20)..... 20**
- 3. DRAIN WATER TEMPERING KIT (OPTIONAL) 22**

1. Parts Manual

1.1. Initial Parts Kit

P/N	DESCRIPTION	Qty
00120.01	Bi Metal Thermometer	1
00201.85	Pump Motor, 1HP, 3Ph, 60 Hz, 220V	1
00206.00	Pump Seal Kit	1
00208.00	Slip Joint Nut Gasket	1
00421.83	Power Rocker Switch, Red	1
00556.60	Reed Switch Magnet -ISI	1
00556.10	Reed Switch-ISI	1
00631.05	Ice Cube Relay 220V 12Amp	1
00707.00	½" Water Solenoid Repair Kit JE	1
00738.15	Solenoid Coil JE 220V	1
03202.00	Thermometer (Capillary)	1
03226.00	Pump O-Ring Gasket	1
03623.00	½ Vac Breaker Repair Kit Watts	1
13003.17	Contactora, 60-Amp	1
13003.50	Contactora, 30-Amp	1
13003.70	Toggle Switch SPDT 20AMP	1
13012.26	Motor Contactora, 220V	1
13403.26	Fuse, 3-Amp/250V Slow Blow	2
13415.47	Heater 3kW (GL-C & EST-66)	1
13417.80	Immersion Heater, 3Ph/1Ph, 208-230V, 10kW	1
13417.92	Heater Thermostat	1
13465.00	Liquid Level Switch, SS	1
13503.00	Rinse Pump Motor EST-44/GLC Wash	1
13503.06	EST-44 Gear Motor Assy	1
13507.65	Cam Bearing Assy (New Dec 2007)	1
13508.70	Heavy Duty Clutch Spring	1

1.2. Exploded View Drawings

1.2.1. Cabinet Assembly

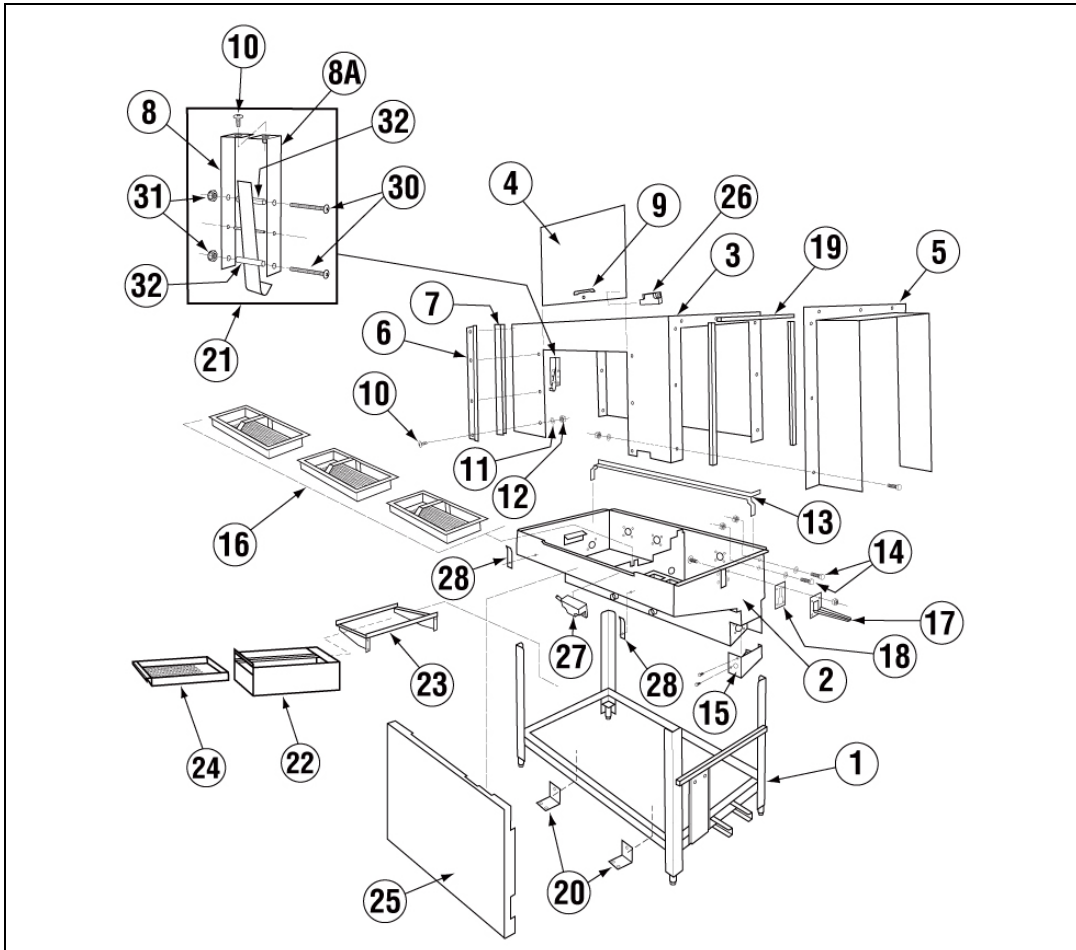

ITEM NO.	NO. REQ'D	P/N	DESCRIPTION
1	1	13939.22	Universal CMA-44/EST Stand
2	1	13939.06	EST-44 Pan L-R
		13939.16	EST-44 Pan R-L
3	1	13939.09	EST-44 Wrapper L-R
		13939.19	EST-44 Wrapper R/L
4	1	01506.30	Door
5	2	13901.10	Wrapper Shield
6	2	01554.30	Door Guide
7	2	00636.10	Door Guide Plastic
8	1	13915.20	Door Latch Bracket
8A	1	13915.26	Door Latch Bracket W/Nut
9	1	00535.30	Door Handle
10	27	00905.00	1/4-20 x 1/2" Trusshead Bolt
11	60	00924.00	1/4" Washer, SS
12	52	00912.00	1/4-20 Nylon Lock Nut
13	2	13906.00	Tray Track Rail
14	8	00914.10	1/4-20 x 5/8" Hex Head Bolt

ITEM NO.	NO. REQ'D	P/N	DESCRIPTION
15	2	13939.50	EST-44 Heater Cover
16	3	13942.00	Strainer Basket, Wash/Rinse EST44/66
17	1	13913.00	Drip Chute
18	1	13542.00	Drip Chute Gasket
19	4	03705.00	Foam Tape
20	2	13010.06	Drain Valve Handle Support
21	1	13701.00	Door Latch
22	1	01579.10	Scrap Trap Body (Univ)
23	1	17579.20	EST Scrap Trap Holder
24	1	01579.20	Scrap Trap Drawer (Univ)
25	1	13912.12	CMA 44 Splash Shield ('07)
26	1	00556.60	Reed Switch Magnet -ISI
27	1	00556.10	Reed Switch-ISI
28	2	13912.81	Splash Shield Clip
29	1	01577.36	Scrap Trap Cover SS (Hi Temp)
30	1	00960.00	8-32x1-1/2" Panhead Screw
31	1	00927.00	8-32 Nylon Lock Nut
32	2	13915.30	Door Latch Bracket Spacer

1.2.2. Control Box Assembly

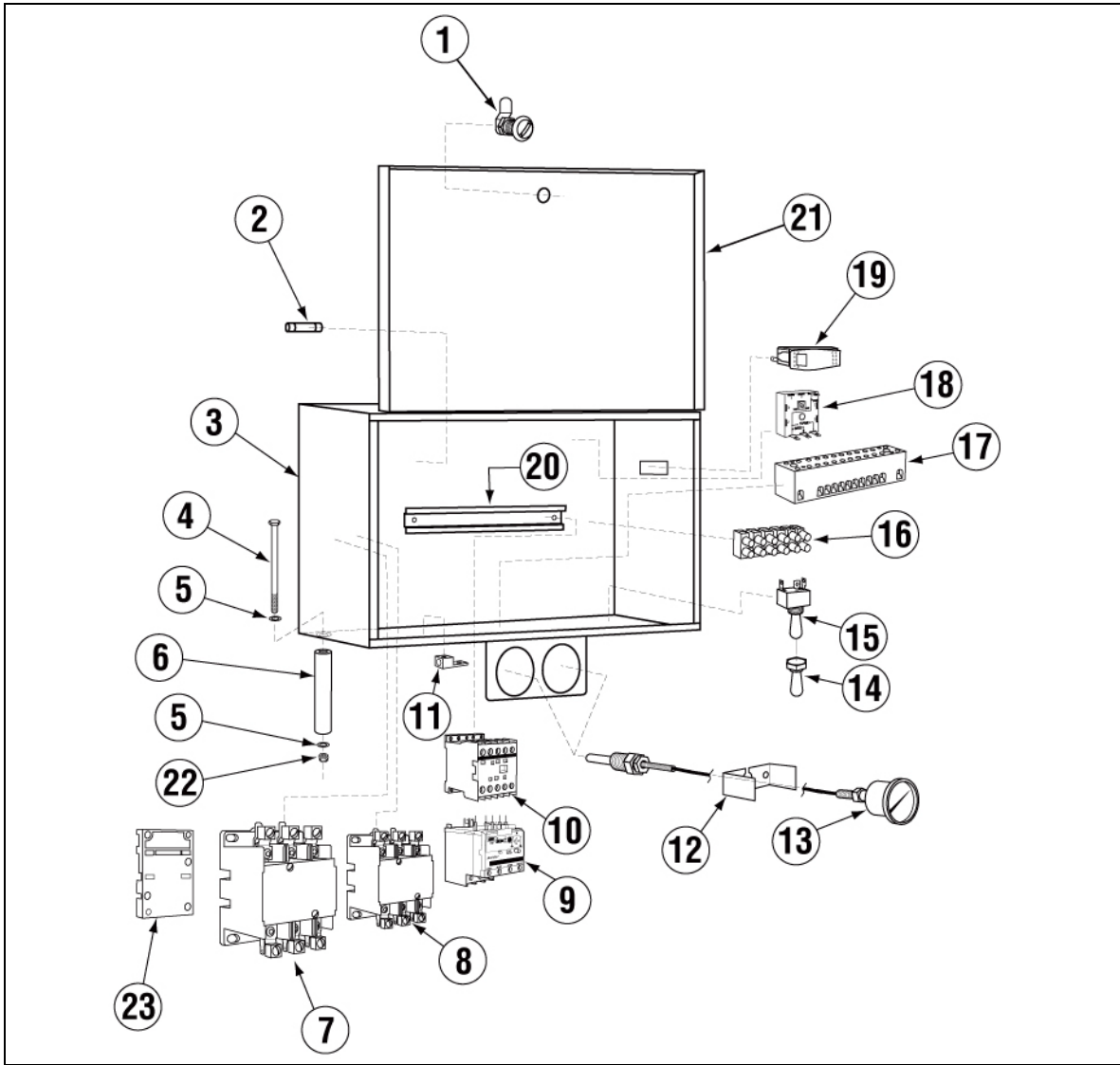

ITEM NO.	NO. REQ'D	P/N	DESCRIPTION
1	1	00449.50	Lock, Keyless
2	2	13403.26	Fuse, 3-Amp/250V Slow Blow
3	1	13941.12	EST-44 Control Box Body
4	4	00909.00	¼-20x3 ¼ SS Hexhead Bolt
5	8	00924.00	¼ SS Washer
6	4	13941.20	EST-44 Control Box Legs
7	1	13003.17	Contactor 60 Amp 3 Pole
8	1	13003.50	Contactor 30 Amp
9	1	13013.45	EST-44 Conv Motor Overload
10	4	13012.26	Motor Contactor, 220V
11	1	13426.50	Ground Block

ITEM NO.	NO. REQ'D	P/N	DESCRIPTION
12	2	03202.08	Thermometer Bracket
13	2	03202.00	Thermometer
14	1	00470.10	Toggle Switch Rubber Boot
15	1	13003.70	Toggle Switch SPDT 20AMP
16	1	00454.06	6-Pole Terminal Block
17	1	15520.00	Power Block 12-Position
18	1	13418.60	Dip Switch Timer 230 V
19	1	00421.83	Power Rocker Switch, Red
20	1	13003.60	Starter DIN Rail
21	1	13941.22	EST-44 Control box lid
22	4	00912.00	¼-20 Nylon Lock Nut
23	2	13003.62	Din Rail Mounting Bracket

1.2.3. Curtain and Optional Vent System

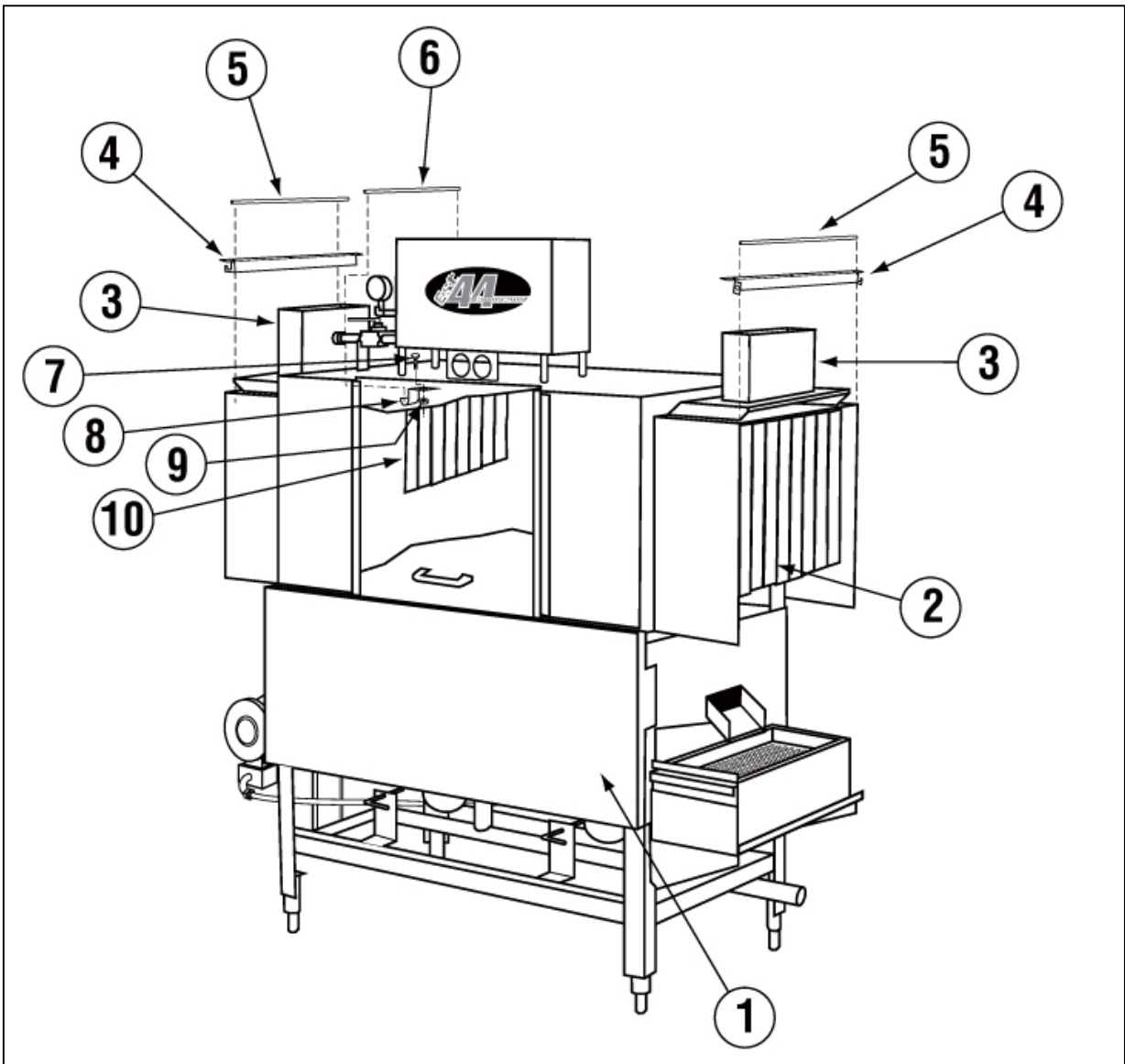

ITEM NO.	NO. REQ'D	P/N	DESCRIPTION
1	1	13912.12	CMA 44 Splash Shield ('07)
2	2	13702.25	Curtain CMA-44(20-5/8" x 15")
3	1	13901.82	Hood Adapter EST-44 (2 pc set)
4	2	13901.30	Outer Wrap Shield Curtain Support
5	2	13705.00	Curtain Rod Short

ITEM NO.	NO. REQ'D	P/N	DESCRIPTION
6	2	13705.10	Curtain Rod Long
7	4	00914.10	1/4-20 X 5/8 Hexhead Bolt
8	2	13901.12	CMA 44 Wash Curtain Support ('07)
9	4	00912.00	1/4-20 Nylon Lock Nut
10	1	13702.35	Curtain CMA-44 (24 5/8" x 11-1/2")

1.2.4. Old Wash Temperature Control System (Square Flange)

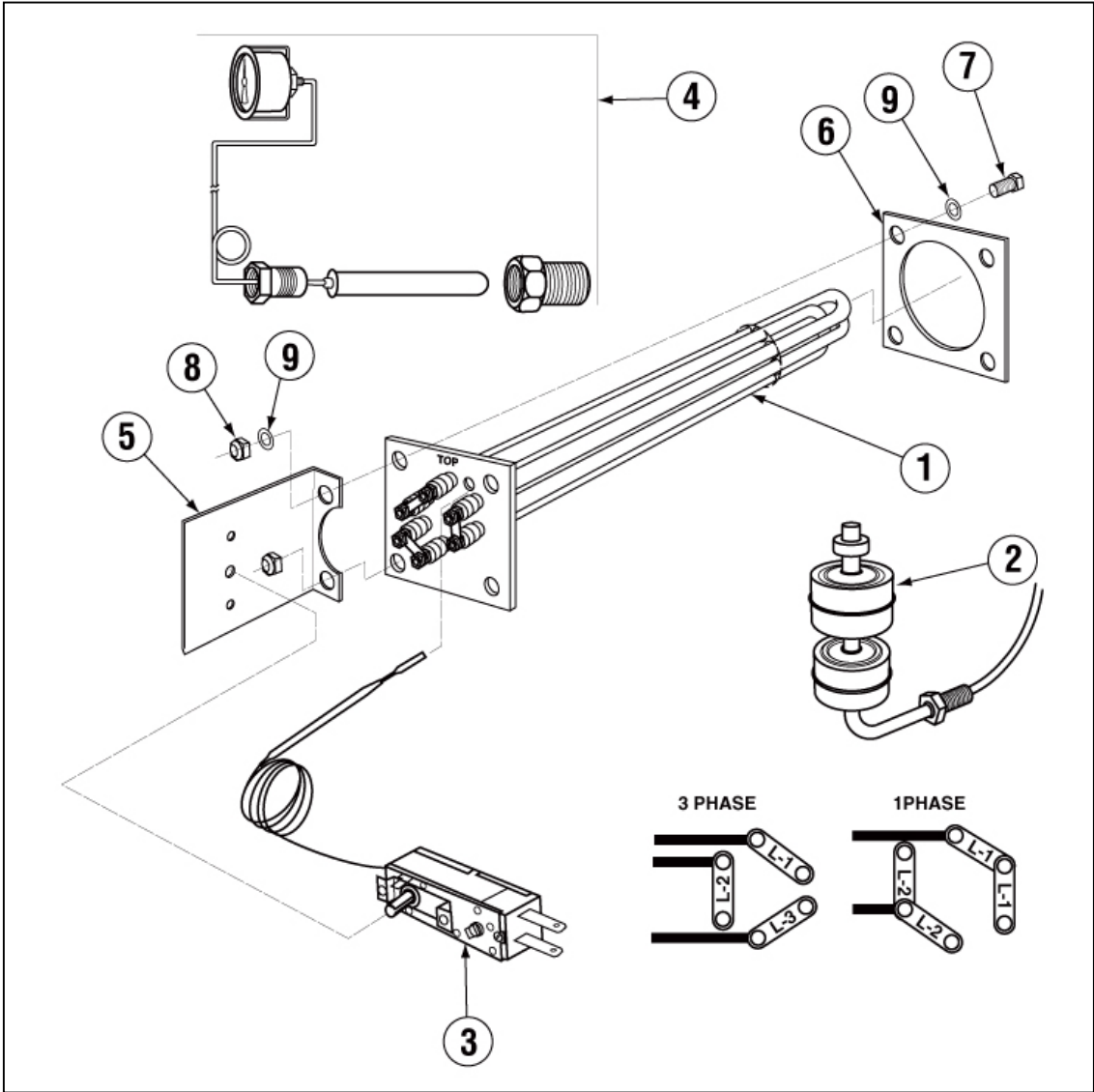

ITEM NO.	NO. REQ'D	P/N	DESCRIPTION
1	1	13417.75	Immersion Heater 3hp/1PH 380V 10kW
	1	13417.80	Immersion Heater 3Ph/1PH 240V 10kW
2	1	13465.00	EST-44/66 Dual Float Switch
3	1	13417.92	EST-66 Heater Thermostat (EGO)
4	1	03202.00	Thermometer

ITEM NO.	NO. REQ'D	P/N	DESCRIPTION
5	1	13416.10	Thermostat Bracket
6	1	13417.45	Heater Gasket
7	4	00901.00	5/16 – 18 x 1" Hexhead Bolt
8	4	13805.00	5/16 – 18 Nylon Nut
9	8	00926.00	5/16" SS washer

1.2.5. New Wash Temperature Control System (Triangular Flange)

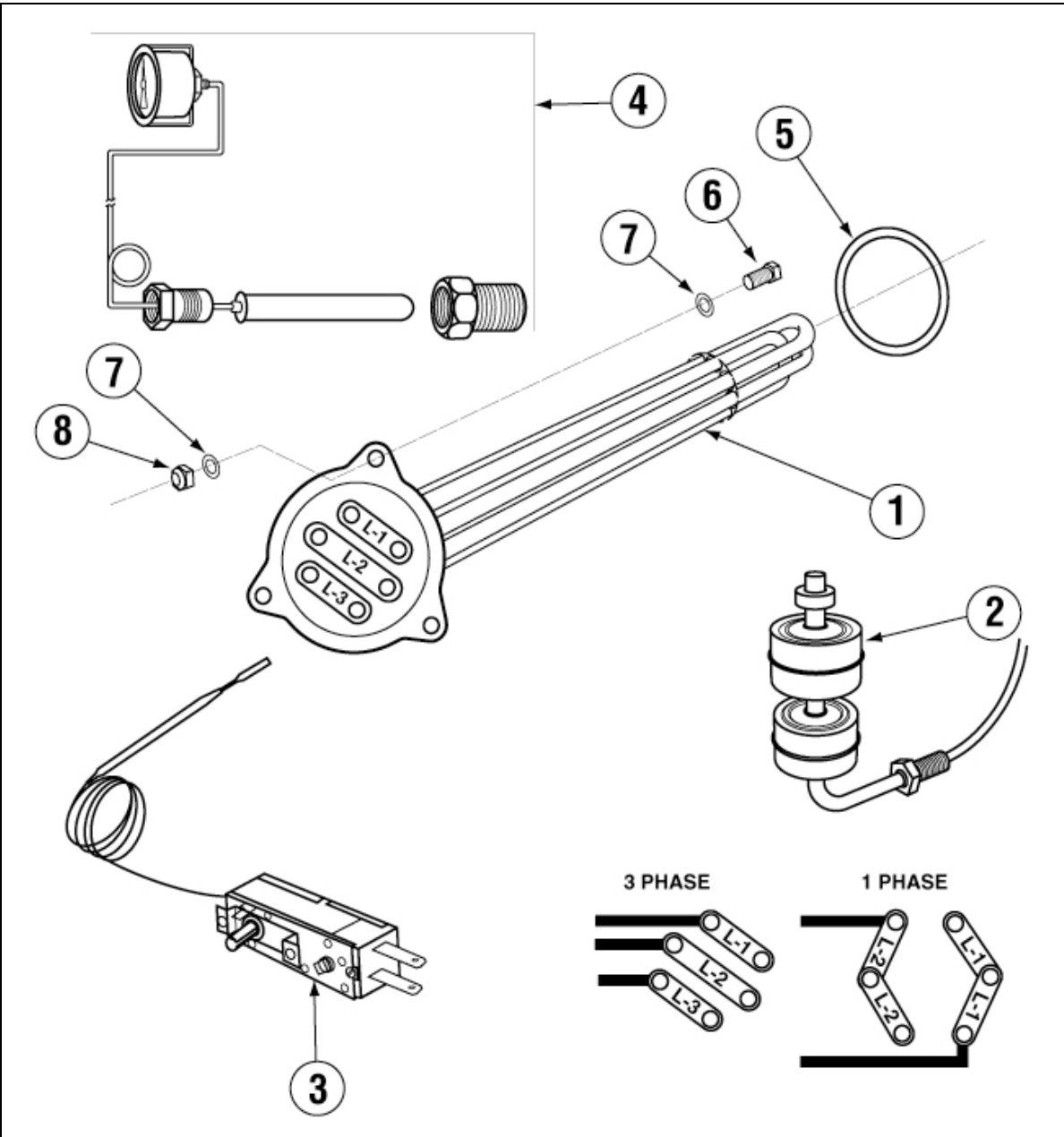

ITEM NO.	NO. REQ'D	P/N	DESCRIPTION
1	1	13422.78	380V 12KW Triangular Immersion Htr.
	1	13422.80	208V 10KW Triangular Immersion Htr.
2	1	13465.00	EST-44/66 Dual Float Switch
3	1	13417.92	EST-66 Heater Thermostat (EGO)
4	1	03202.00	Thermometer

ITEM NO.	NO. REQ'D	P/N	DESCRIPTION
5	1	13417.45	Heater Gasket
6	4	00914.00	1/4-20 X 3/4 Hexhead Bolt
7	4	00912.00	1/4-20 Nylon Lock Nut
8	8	00924.00	1/4" SS washer

1.2.6. Rinse Temperature Control System

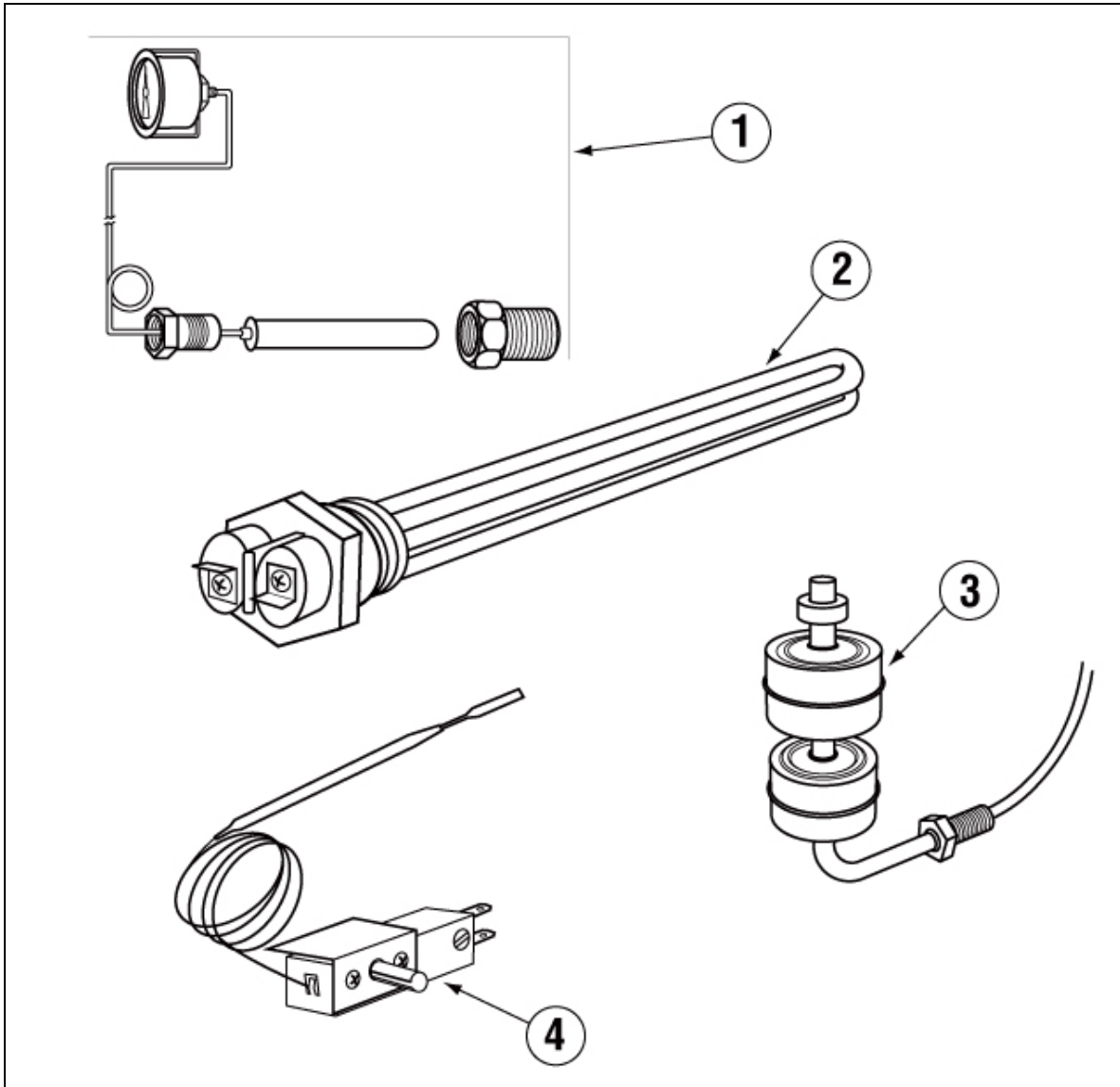

ITEM NO.	NO. REQ'D	P/N	DESCRIPTION
1	1	03202.00	Thermometer
2	1	13415.47	Heater 3kW (GL-C & EST-66)
3	1	13465.00	Float Switch
4	1	13417.92	EST-66 Heater Thermostat (EGO)

1.2.7. Wash Pump Assembly

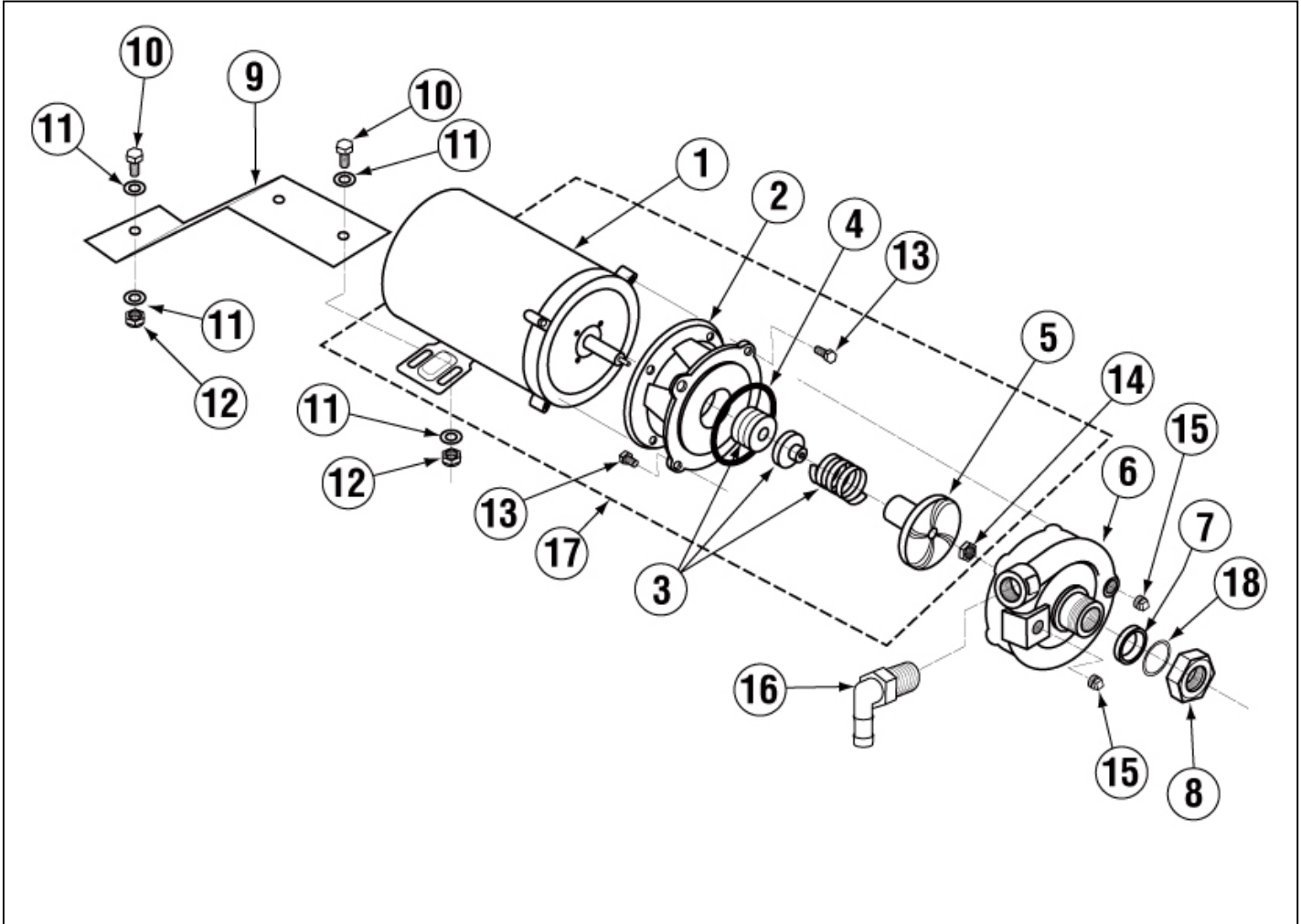

ITEM NO.	NO. REQ'D	P/N	DESCRIPTION
1	1	00201.85	Pump Motor, 1HP, 3Ph, 60 Hz, 220V
2	1	03224.00	Pump Base Mount
3	1	00206.30	Pump Seal Kit New
4	1	03226.00	Pump O-Ring Gasket
5	1	03222.10	Impeller (Open) SS
6	1	04206.00	Pump Cover
7	1	00208.00	Slip Joint Nut Gasket
8	1	04204.00	Compression Nut, 2.5"
9	1	13916.40	Motor Support Bracket

ITEM NO.	NO. REQ'D	P/N	DESCRIPTION
10	3	00906.00	1/4-20 x 1/2" Hex Bolt
11	6	00922.00	1/4" Lock Star Washer
12	3	00912.00	1/4-20 Nylon Lock Nut
13	8	00921.00	3/8-16 x 3/4" SS Hex Head Bolt
14	1	13829.00	7/16-20 Thin Nylon Lock Nut
15	2	00238.00	3/8" Male Plug
16	1	13939.30	1" Elbow 90Deg MPT x Barb
17	1	00200.85	Motor Assembly, 1HP, 3Ph, 220V, 60 Hz**
18	1	00208.20	Slip Joint Nut Friction Ring

*For EST-44 R-L only.

**Includes Items 1, 2, 3, 4, 5 and 14.

1.2.8. Rinse Pump Assembly

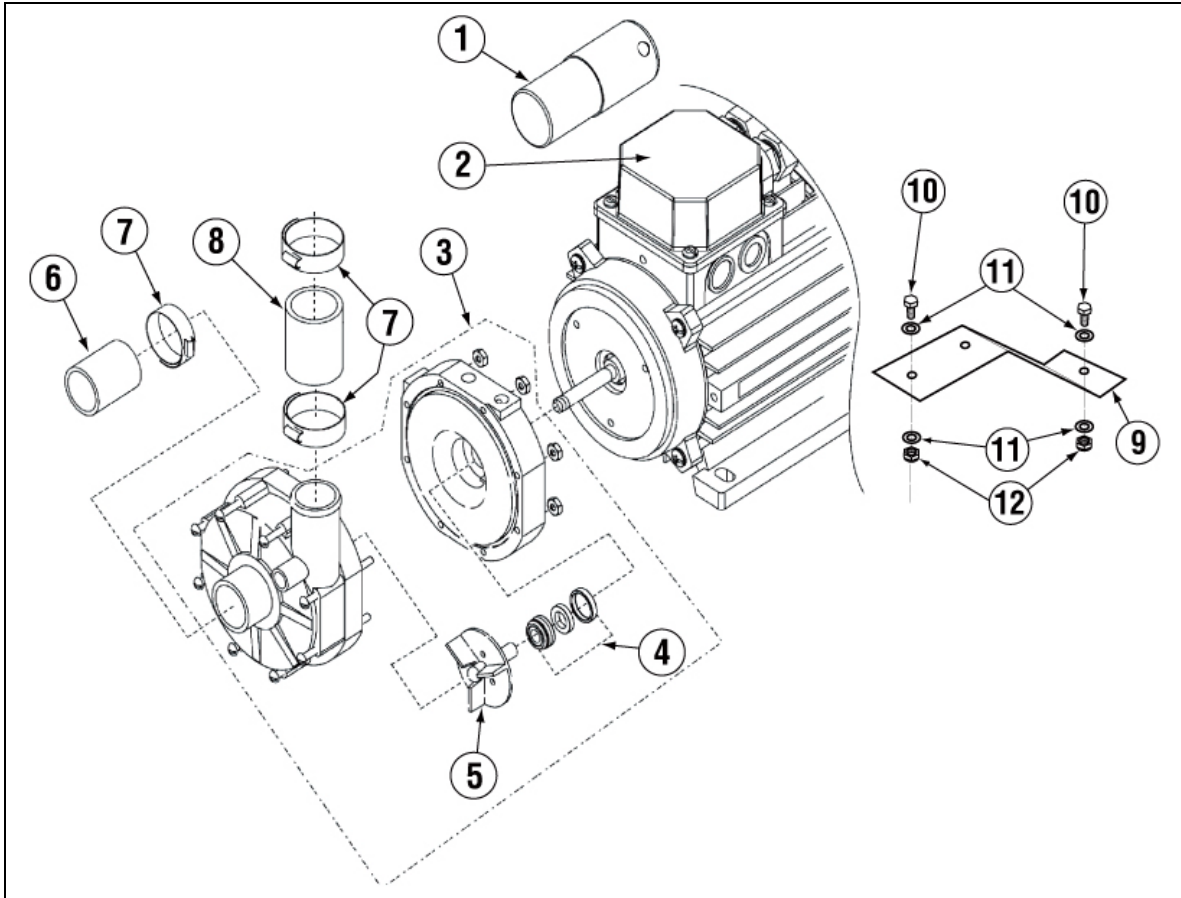

ITEM NO.	NO. REQ'D	P/N	DESCRIPTION
1	1	43070.00	Capacitor 6.3uF/370 VAC
2	1	13503.00	Pump Motor 230VAC/1Ph
3	1	43072.00	Pump Kit (includes 4-5)
4	1	43073.00	Wash Pump Shaft Seal
5	1	43074.00	Wash Pump Impeller
6	6	43075.00	Hose 1" ID x 1 1/4" OD

*Not shown

ITEM NO.	NO. REQ'D	P/N	DESCRIPTION
7	3	03101.00	Hose Clamp # 16 1"
8	6	03108.60	Transfer Hose 1" Reinforced
9	1	13916.45	EST-44 Final Rinse Motor Bracket*
10	3	00906.00	1/4-20 x 1/2" Hex Bolt
11	6	00922.00	1/4" Lock Star Washer
12	3	00912.00	1/4-20 Nylon Lock Nut

1.2.9. Drain System Assembly

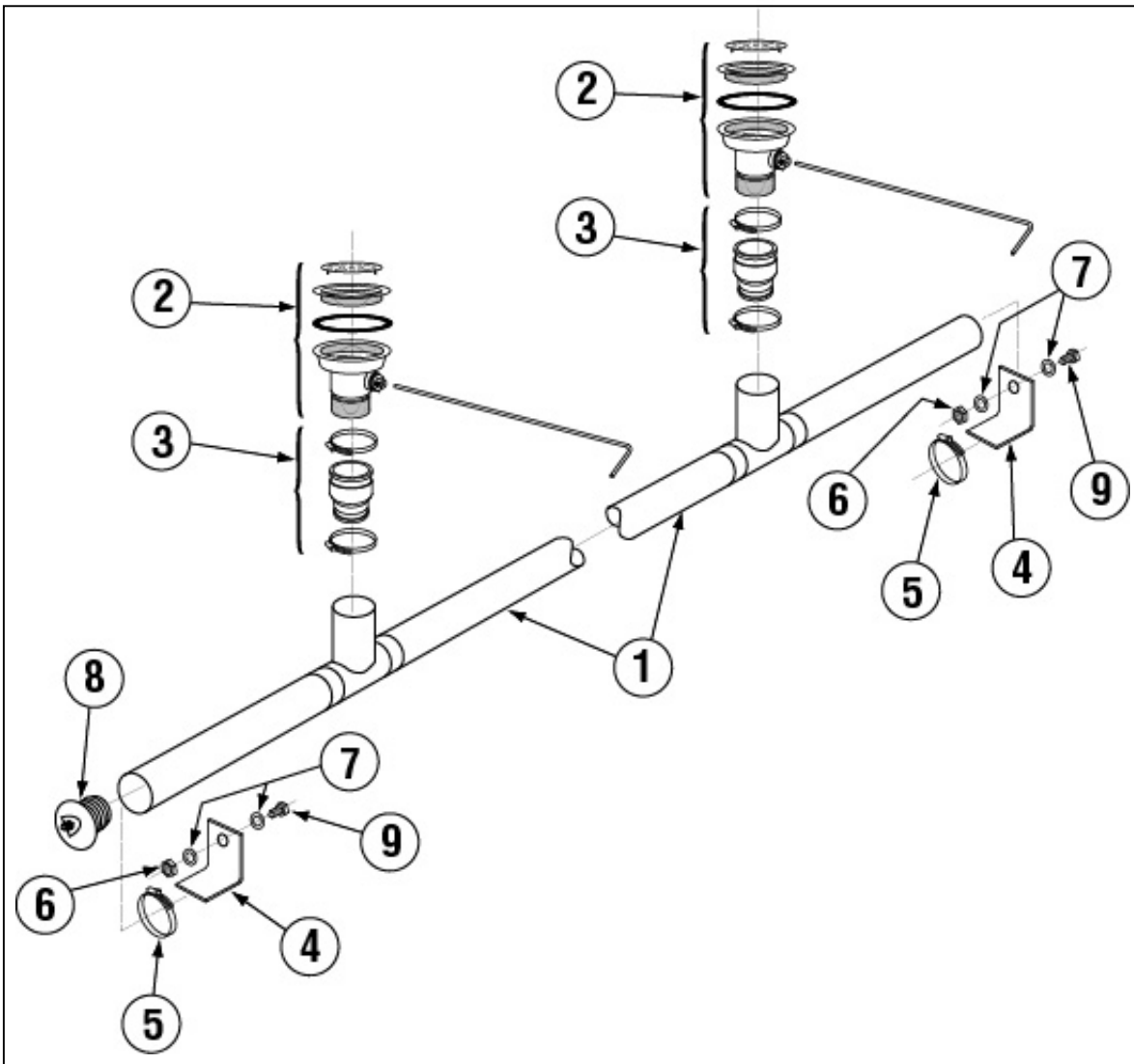

ITEM NO.	NO. REQ'D	P/N	DESCRIPTION
1	1	13001.85	Drain Manifold
2	2	20500.06	Waste Drain Valve
3	2	01317.17	1-1/2" x 2" No Hub
4	2	13001.26	Drain Support Bracket
5	2	50109.00	Hose Clamp

ITEM NO.	NO. REQ'D	P/N	DESCRIPTION
6	2	00912.00	1/4-20 Lock Nut
7	4	00924.00	1/4" Washer, SS
8	1	13024.00	Dynamite Plug, 2"
9	2	00906.0	1/4-20 x 1/2" Hex Head Bolt

1.2.10. Plumbing System Assembly (Auto-Fill)

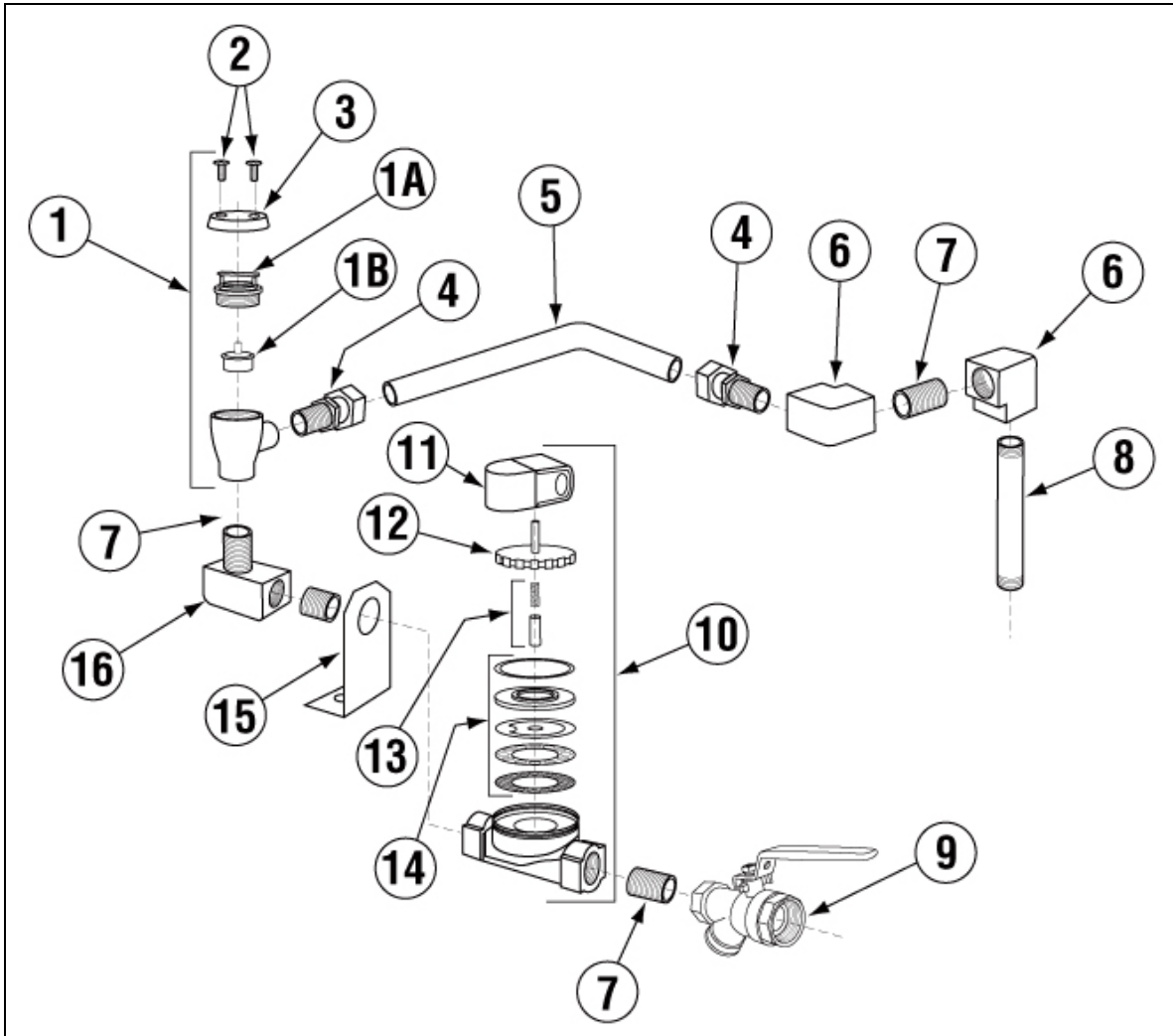

ITEM NO.	NO. REQ'D	P/N	DESCRIPTION
1	1	03624.00	1/2" Vacuum Breaker, Watts**
1A	1	03624.25	1/2" Vacuum Breaker Bonnet
1B	1	03623.00	1/2" Vacuum Breaker Repair Kit
2	2	00421.51	6-32 x 1/4" SS Panhead Screw
3	1	00739.50	Vacuum Breaker Cap
4	2	00760.00	5/8 Comp x 1/2 MIP Adapter
5	1	13608.00	EST-44 Water Inlet Tube SS
6	2	41030.10	1/2 90 Deg Ell Fx F Brass
7	3	00742.00	Nipple Brass 1/2 x 1 1/2

ITEM NO.	NO. REQ'D	P/N	DESCRIPTION
8	1	00747.10	Nipple Brass 1/2 x 5
9	1	41062.00	1/2 Strainer Ball Valve
10	1	03603.15	1/2" Water Solenoid Valve 220V, JE*
11	1	00738.15	Water Solenoid Valve Coil, 220V, 3/4" & 1/2"
12	1	03603.20	1/2" Water Solenoid Valve Bonnet
13	1	00786.00	Water Solenoid Plunger with Spring
14	1	00707.00	1/2" Water Solenoid Valve Repair Kit
15	1	01525.06	Plumbing Support Bracket
16	1	00745.00	1/2 90 Deg Street Elbow

1.2.11. Plumbing System Assembly (Final Rinse)

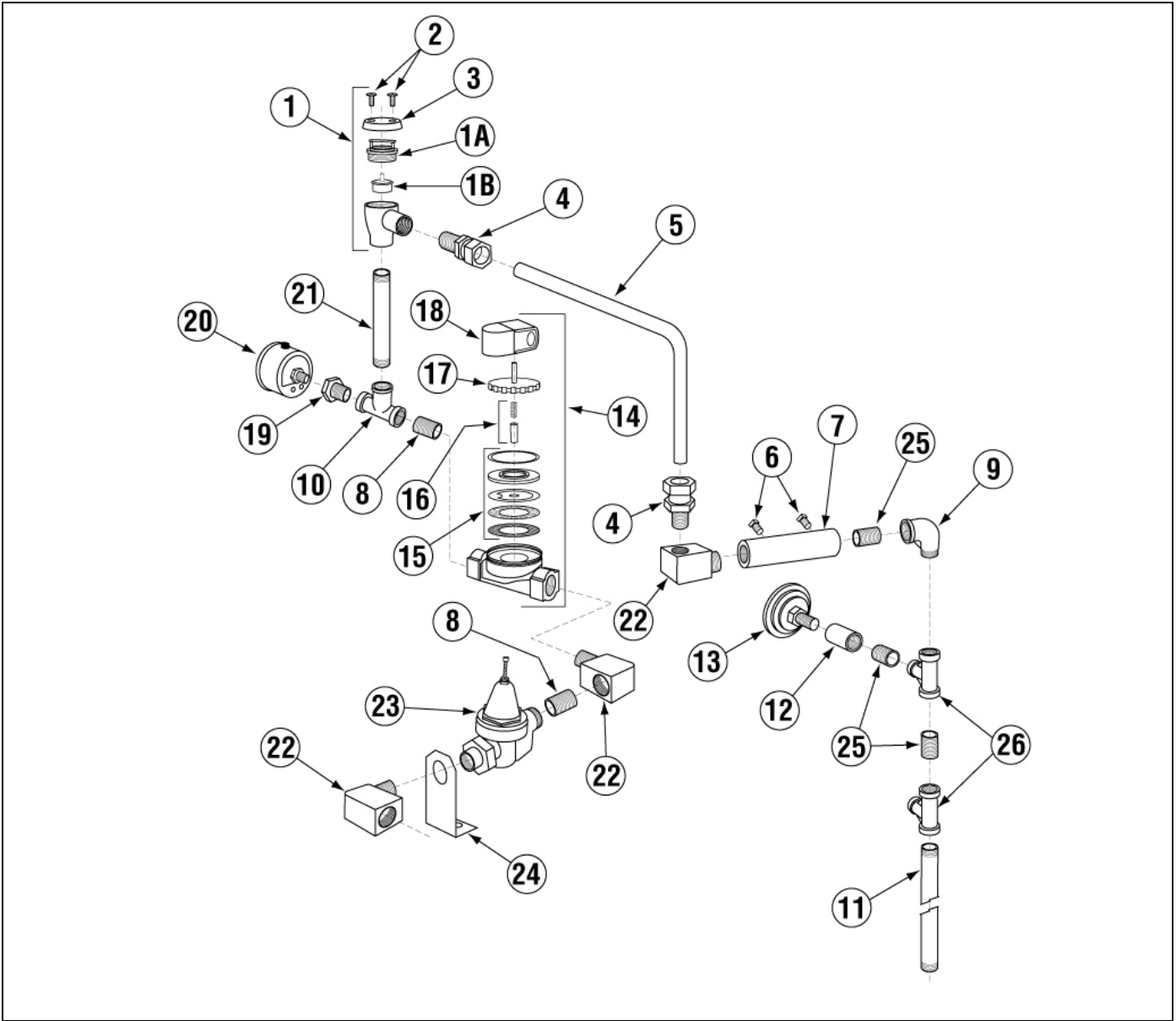

ITEM NO.	NO. REQ'D	P/N	DESCRIPTION
1	1	03624.00	1/2" Vacuum Breaker, Watts**
1A	1	03624.25	1/2" Vacuum Breaker Bonnet
1B	1	03623.00	1/2" Vacuum Breaker Repair Kit
2	2	00421.51	6-32 x 1/4" SS Panhead Screw
3	1	00739.50	Vacuum Breaker Cap
4	2	00760.00	5/8 Comp x 1/2 MIP Adapter
5	1	13608.50	44 Final Rinse Plumbing Tube
6	2	03232.00	1/8 Male Plug
7	1	13669.21	Mixing Chamber SS
8	3	00742.00	Nipple Brass 1/2 x 1 1/2
9	1	13620.10	Street Elbow 1/2" SS 316
10	1	00743.10	1/2" Tee, F x F x F
11	1	13307.00	Final Rinse Tube, 23-1/2"
12	1	00740.00	Coupling Adapter 1/2"x1/4"SS FxF

ITEM NO.	NO. REQ'D	P/N	DESCRIPTION
13	1	00120.01	Bi Metal Thermometer
14	1	03603.15	1/2" Water Solenoid Valve 220V, JE*
15	1	00707.00	1/2" Water Solenoid Valve Repair Kit
16	1	00786.00	Water Solenoid Plunger with Spring
17	1	03603.20	1/2" Water Solenoid Valve Bonnet
18	1	00738.15	Water Solenoid Valve Coil, 220V, 3/4" & 1/2"
19	1	13604.00	1/2 x 1/4 Bushing Brass
20	1	13605.45	Pressure Gauge (CMA-180)
21	1	00747.10	Nipple Brass 1/2 x 5
22	3	00745.00	1/2 90 Deg Street Elbow
23	1	13602.20	1/2" Pressure Regulator
24	1	01525.06	Plumbing Support Bracket
25	3	13629.00	Nipple SS 1/2 x Close
26	1	13630.00	Tee 1/2 FxFxF SS

1.2.12. Wash System Assembly

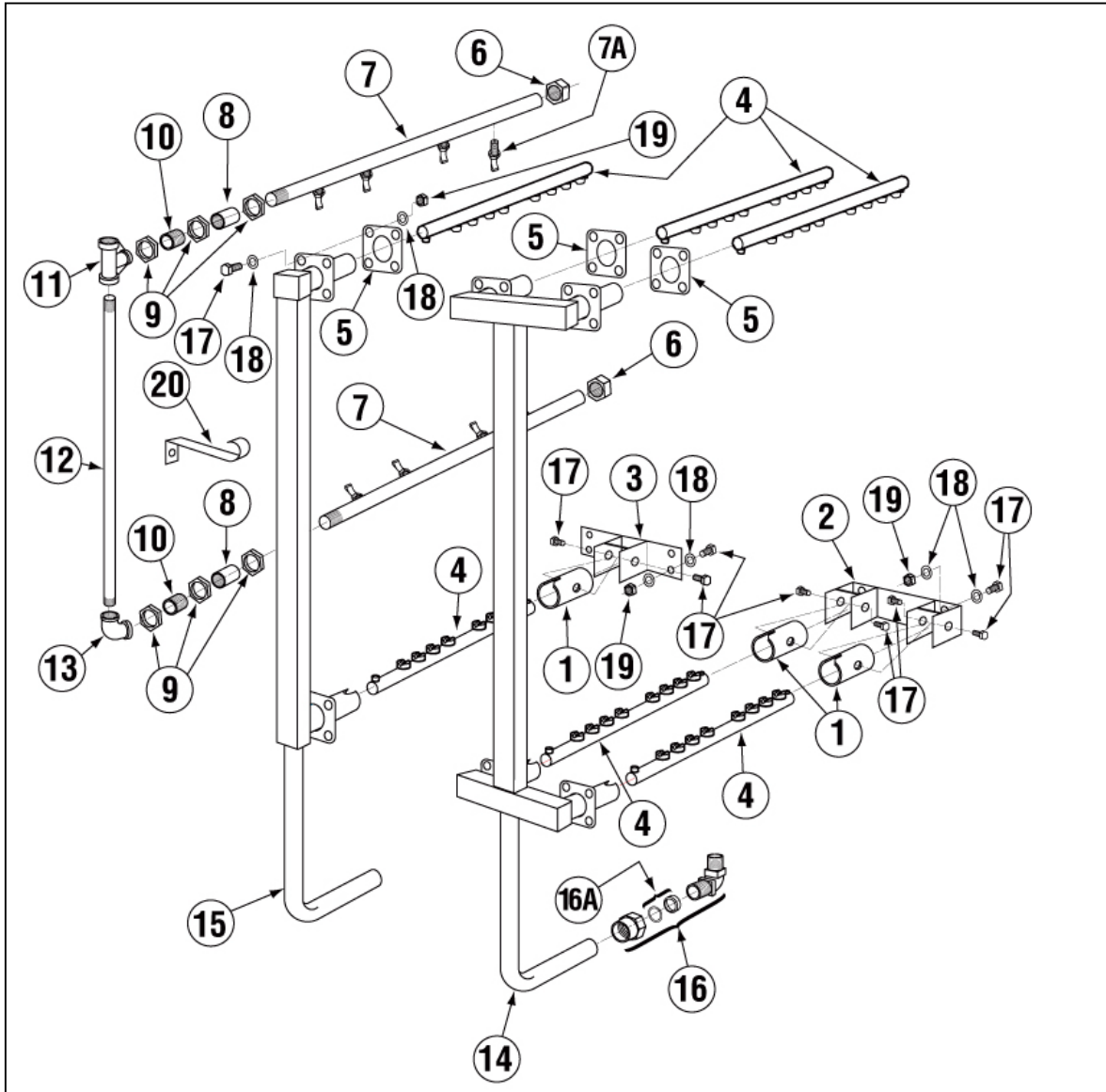

ITEM NO.	NO. REQ'D	P/N	DESCRIPTION
1	6	13305.06	Spray Arm End Cap
2	2	13327.06	Socket Bracket, Double
3	2	13327.26	Socket Bracket, Single
4	6	13303.16	Spay Arm
5	6	04306.10	Square Manifold Gasket
6	2	13310.00	1/2" Cap, Brass
7	2	13304.83	Final Rinse Spay Arm*
7A	8	13304.66	Final Rinse Spray Jets, SS
8	2	13618.00	1/2" Coupling
9	4	00721.20	1/2" Jamb Nut, Brass
10	3	13629.00	1/2" Close Nipple, SS

ITEM NO.	NO. REQ'D	P/N	DESCRIPTION
11	1	13630.00	1/2" F x F x F Tee, SS
12	1	13307.00	Final Rinse Tube, 23-1/2"
13	1	13628.00	1/2" 90° Elbow, F x F, SS
14	1	13301.12	Wash Manifold
15	1	13301.39	Rinse Manifold
16	1	00213.00	1" Ford Adapter, MIP x PJ Tube**
16A	1	00225.00	1" Compression Gasket
17	32	13305.40	Shoulder Bolt
18	64	00924.00	1/4" SS Washer
19	32	00912.00	1/4-20 Nylon Lock Nut
20	1	13304.53	Long Support Bracket

1.2.13. Rocker Arm Assembly

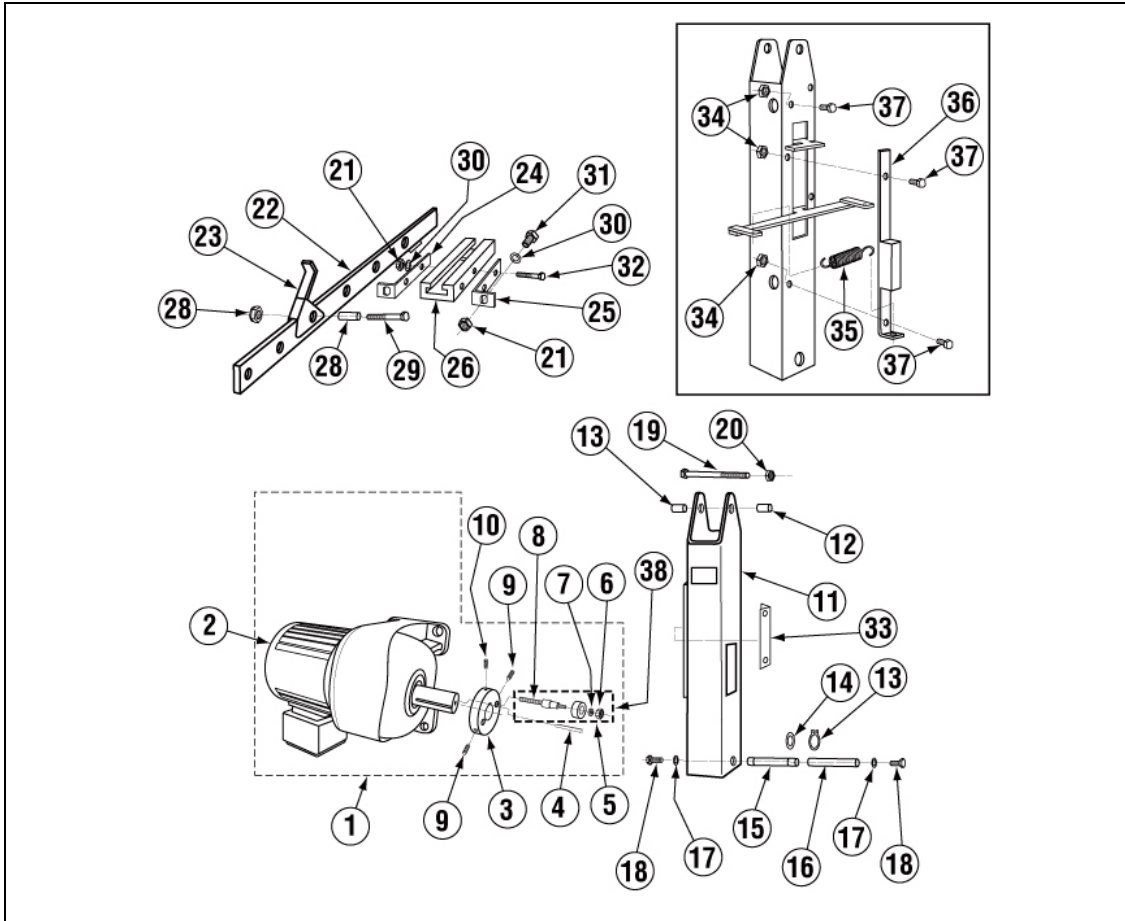

ITEM NO.	NO. REQ'D	P/N	DESCRIPTION
1	1	13571.00	EST Conveyor Drive Ass
2	1	13503.06	EST-44 Gearbox Motor Ass
3	1	13505.14	EST-44 Drive Cam
4	1	13505.20	Keyway (Cam)
5	1	13507.20	Cam Bearing Only
6	1	13805.00	5/16-18 Nylon Insert Lock Nut
7	1	13507.11	Cam Bearing Shaft Spacer
8	1	13507.12	Cam Bearing Shaft
9	2	00935.22	1/4-28 x 1/2" Brass Tip Set Screw
10	1	13816.00	5/16-18 X 1/2 Socket Set Screw
11	1	13508.12	CMA 44 Rocker Arm
12	2	13513.10	Rocker Arm Spacer
13	2	13509.52	7/8" ID External Lock Ring
14	2	13509.53	1" ID Brass Washer
15	1	13509.12	CMA 44 Rocker Shaft Bearing
16	1	13510.10	Bearing Shaft
17	2	00922.00	1/4" Lock Star Washer
18	2	00914.00	1/4-20 x 3/4" Hex Head Bolt
19	1	13808.00	1/2-13 x 3-1/2"

ITEM NO.	NO. REQ'D	P/N	DESCRIPTION
20	1	13809.00	1/2-13 Nylon Lock Nut
21	1	00912.00	1/4-20 Nylon Lock Nut
22	1	13514.85	Conveyor Bar (5 Dogs) (CMA-44)
23	5	13515.00	Conveyor Dog, SS
24	1	13514.82	Left Conveyor Bar Bracket
25	1	13514.84	Right Conveyor Bar Bracket
26	1	13521.50	Conveyor Bar Slide Bearing
27	10	13520.00	Conveyor Dog Bearing
28	5	13806.00	3/8" Nylon Lock Nut
29	5	13818.00	3/8-16 x 1-3/4" Hex Head Bolt
30	2	00924.00	1/4" SS Washer
31	2	00914.10	1/4-20 x 5/8" Hex Head Bolt
32	1	00903.00	1/4-20 x 1-3/4" Hex Head Bolt
33	1	13505.06	Cam Guide
34	4	00912.00	1/4-20 Nylon Lock Nut**
35	1	13508.70	Heavy Duty Clutch Spring
36	1	13508.26	Rack Saver Clutch Bar
37	4	00914.00	1/4-20 x 3/4" Hex Head Bolt**
38	1	13507.65	Cam Bearing Assy (12/07)

1.2.14. Start Switch and Rinse Switch Assembly

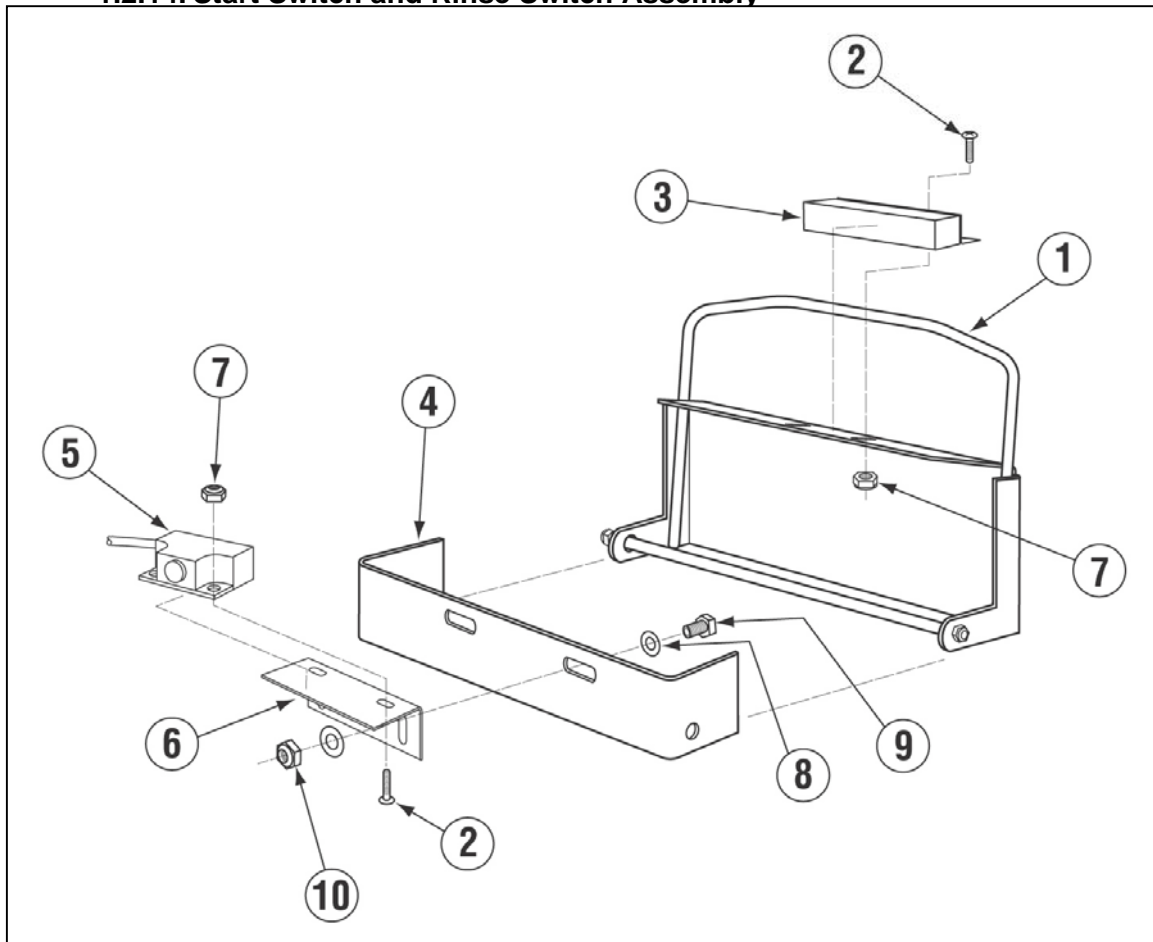

ITEM NO.	NO. REQ'D	P/N	DESCRIPTION
1	1	13408.61	Actuator Arm
2	4	00907.50	6-32 x 3/8" Pan Head Screw
3	1	00556.60	Reed Switch Magnet-ISI
4	1	13408.62	Actuator Bracket
5	1	00556.10	Reed Switch-ISI
6	1	13408.63	Reed Switch Bracket
7	4	00965.00	6-32 Nylon Lock Nut
8	4	00924.00	1/4" SS Washer
9	4	00906.00	1/4" -20 x 1/2" Hex Head Bolt
10	4	00912.00	1/4" - 20 Nylon Lock Nut
11	1	13408.60	Actuator Assy.* Not shown

*Includes Items 1, 4,7,8 and 9.

1.2.15. Optional E-Temp Heater

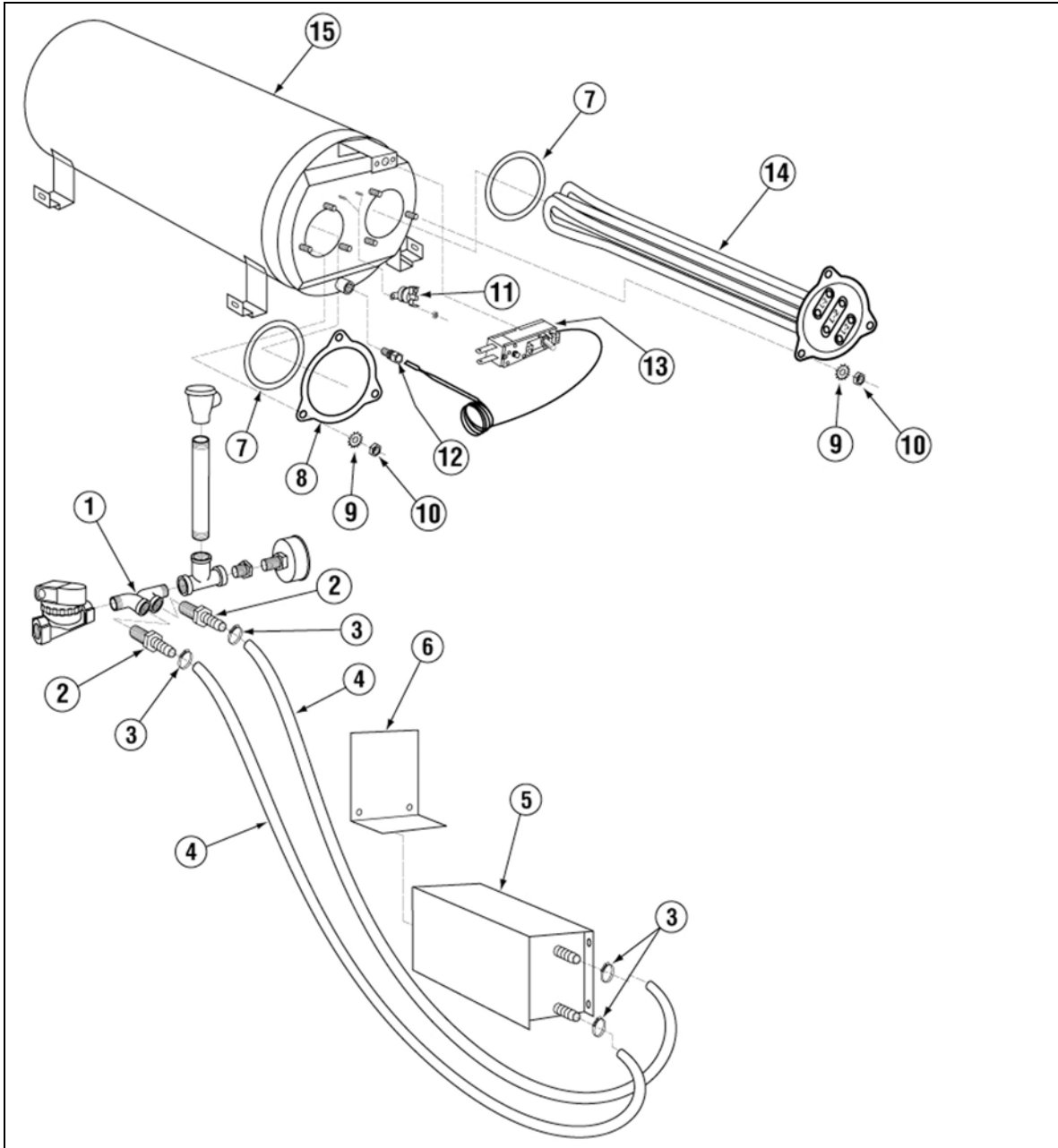

ITEM NO.	NO. REQ'D	P/N	DESCRIPTION
1	1	13620.20	Booster Heater 1/2 In/Out Adapter
2	2	40014.00	1/2m x 1/2 Barb Straight
3	4	03101.00	Hose Clamp # 16 1"
4	AR	03107.50	Flexible Red Hose 1/2" Horizon 250
5	1	13951.10	E-Temp Booster Shroud - Zoppas
6	1	13951.12	E-Temp Booster Access Cover
7	2	15518.10	Gasket for Triangular Flange Heater
8	1	13950.20	E-Temp Tank Plug

ITEM NO.	NO. REQ'D	P/N	DESCRIPTION
9	6	00924.00	1/4 SS Washer
10	6	00912.00	1/4-20 Nylon Lock Nut
11	1	17523.51	Hi Limit Switch 250Deg
12	1	40116.00	1/4 Comp x 1/4 MIP Ftg
13	1	13417.92	Heater Thermostat
14	1	13422.72	240V 10KW Triangular Immersion Htr*
15	1	13951.20	E-Temp Heater Tank (40F Rise)

* Note : Use two heaters for 70 F Rise.

2. Table Limit Switch Instructions (P/N 13469.20)

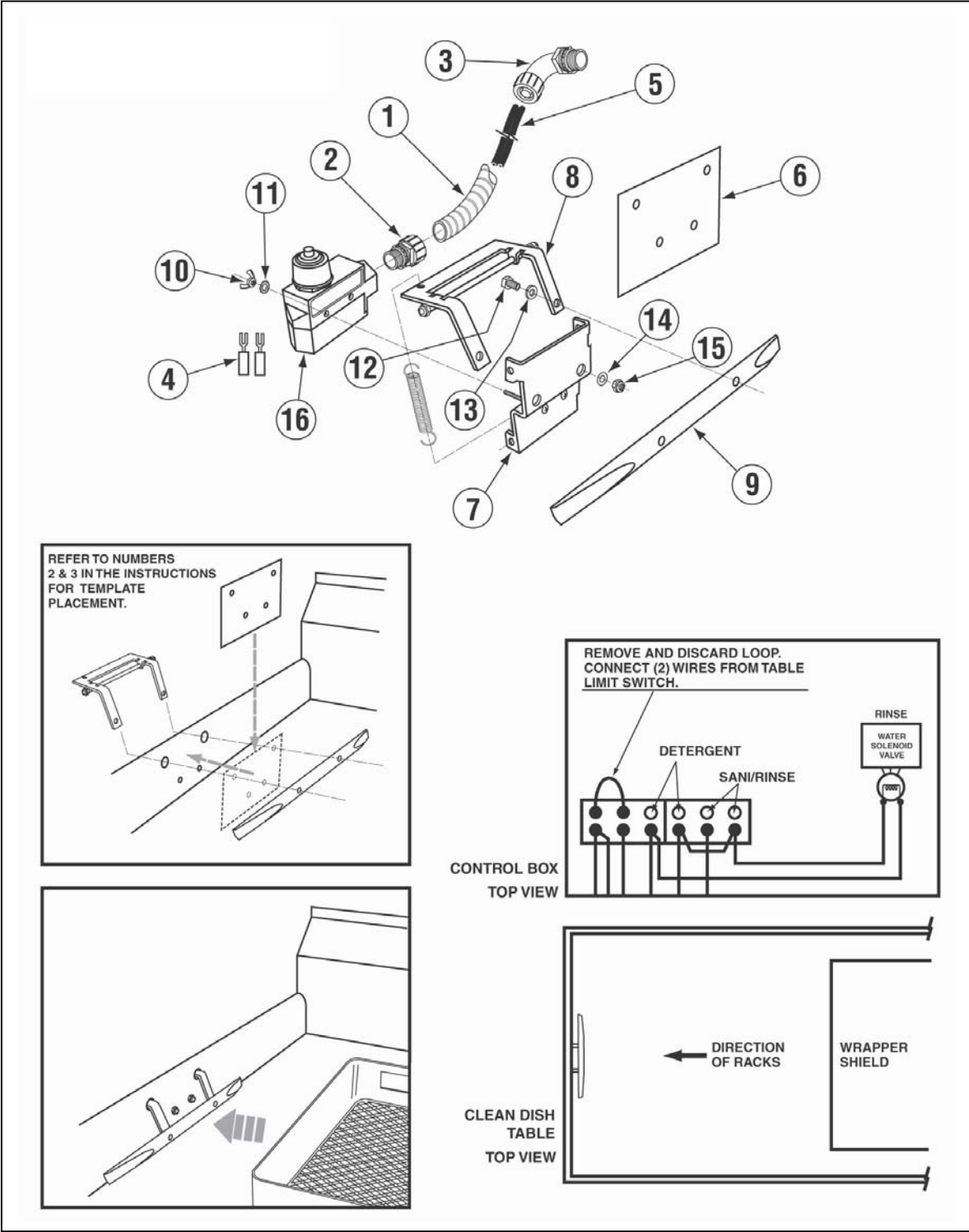

	QTY	P/N	DESCRIPTION
1	12 FT	00400.00	Conduit 3/8 sealtite
2	1	00401.00	ST-3/8 straight connector
3	1	00402.00	ST-90 deg.3/8 connector
4	2	00446.00	Fork tongue connector
5	24 FT	00529.00	Wire 18 gauge black
6	1	13427.60	Template kit
7	1	13427.61	Mounting bracket
8	1	13427.62	Actuator
9	1	13427.63	Bumper
10	2	03817.00	6-32 wing nut
11	2	03814.10	Lock star washer
12	2	00914.10	1/4-20 x 5/8 hexhead bolt
13	2	00968.00	1/4 split lock washer
14	2	00924.00	1/4 ss washer
15	2	00912.00	1/4-20 nylon lock nut
16	1	13427.10	Limit switch

Instructions:

- Determine the approximate centerline of the dish rack as it travels down the clean table.
- Place the template from the template kit (6) with the lower edge resting on the table surface, against the end roll, and centered along the dish rack's line of travel. Mark the positions of the four holes and follow up with a center punch.
- Drill a 1/8" hole through each position .The upper two holes then drilled out to 1/2".
- Fasten the template with two bolts and nuts from the template kit (6).The lower holes then drilled out to 3/8".
- From the outside, place the mounting bracket (7) halfway through the 3/8" lower holes on the table and the hinged actuator (8) through two 1/2" upper holes in the table.
- Secure the bumper (9) by tightening the two bolts (12) with lock washers (13) through the two holes in the actuator.
- Push the mounting bracket all the way into the holes in the table and tighten it with two lock nuts (15) and two washers (14).
- Attach the conduit (1) between the control box and the table limit switch (16). Run two wires (5) through the conduit and conduit connectors (2,3), and attach one to the COMMON terminal on table limit switch, and the other to the normally OPEN terminal, using two fork tongue connectors (4). Secure the table limit switch on the mounting bracket with two wing nuts (10). Remove jumper from the optional table limit switch connection in the control box (see note 1 of the wiring diagram). Then, attach the other ends of the two wires to the terminal block (it does not matter which table limit switch wire you attach to either terminal because it is only a loop).

3. Drain Water Tempering Kit (Optional)

