

# Owner's Manual

Keep with machine for reference

## MODEL CMA-180UC

INSTALLATION & OPERATION

Rev 1.15B



**CMA DISHMACHINES**  
**12700 KNOTT AVENUE**  
**GARDEN GROVE, CALIFORNIA 92841**  
**800-854-6417**  
**FAX 714-895-2141**

[www.cmadishmachines.com](http://www.cmadishmachines.com)



# TABLE OF CONTENTS

## MODEL CMA-180UC

<b>1. SPECIFICATIONS .....</b>	<b>2</b>
1.1. CMA-180UC .....	2
1.2. CMA-180UC OPERATIONAL CYCLE.....	3
<b>2. GETTING STARTED.....</b>	<b>5</b>
2.1. INTRODUCTION TO CMA-180UC .....	5
2.2. RECEIVING AND INSTALLATION.....	6
2.2.1. <i>Electrical</i> .....	6
2.2.2. <i>Plumbing</i> .....	6
2.2.3. <i>BETA Detergent And Rinse Dispenser (Optional)</i> .....	7
2.2.4. <i>NOVA Detergent and Rinse Dispenser (Optional)</i> .....	8
2.2.5. <i>Safe Temp Feature</i> .....	10
2.2.6. <i>Water Tempering Kit</i> .....	11
2.2.7. <i>Booster Heater Setup</i> .....	12
2.2.8. <i>Installers Checklist</i> .....	12
<b>3. OPERATION .....</b>	<b>13</b>
3.1. INITIAL SETUP .....	13
3.1.1. <i>Dema Valve and Dema Flow Disc (New Models)</i> .....	13
3.1.2. <i>Rinse Pressure Regulator (Old Models Prior January 2008)</i> .....	13
3.1.3. <i>Rinse and Wash Temperatures</i> .....	13
3.1.4. <i>Post Instructions</i> .....	13
3.2. STARTUP PROCEDURES.....	13
3.3. OPERATING AND CLEANING INSTRUCTIONS .....	14
3.4. PREVENTIVE MAINTENANCE CHART .....	15
3.5. QUICK SERVICE GUIDE.....	16
3.6. TROUBLESHOOTING.....	17
<b>4. PARTS KIT .....</b>	<b>20</b>
4.1. INITIAL PARTS KIT (P/N 1100.66).....	20
4.2. OPTIONAL DRAIN PUMP KIT.....	21
4.3. OPTIONAL DRAIN PUMP—INSTALLATION INSTRUCTIONS .....	22
<b>5. CUSTOMER NOTICE .....</b>	<b>24</b>
<b>6. ELECTRICAL DIAGRAM.....</b>	<b>25</b>

# 1. Specifications

<b>1.1. CMA-180UC</b>	<b>METRIC EQUIVALENT</b>	
<b>WATER CONSUMPTION</b>		
PER RACK	.86 GAL.	(3.25 L)
PER HOUR	20.6 GAL.	(77.8 L)
<b>OPERATING CYCLE</b>		
WASH TIME-SEC	94	94
RINSE TIME-SEC	16	16
DWELL TIME-SEC	10	10
TOTAL CYCLE	2 MIN.	2 MIN.
<b>OPERATING CAPACITY</b>		
RACKS PER HOUR	30	30
WASH TANK CAPACITY	2.5 GAL.	(9.46 L)
PUMP CAPACITY	38 GPM	(144 LPM)
<b>WATER REQUIREMENTS</b>		
REQUIRED MINIMUM TEMP. *	110°F	(43°C)
RECOMMENDED TEMP. **	140°F	(60°C)
WATER INLET	½"	1.27cm
DRAIN CONNECTION	1"	2.54cm
RINSE PRESSURE SET	20 PSI±5 PSI	1.41 kg/cm <sup>2</sup>
<b>CYCLE TEMPERATURES</b>		
WASH-°F	150°F -160°F	(65.5°C/71°C)
RINSE -°F	180°F -195°F	(82°C/90°C)
<b>FRAME DIMENSIONS</b>		
DEPTH	25"	(63.5 cm)
WIDTH	24"	(60.96 cm)
HEIGHT	33 ¼"	(84.45 cm)
MAX CLEARANCE FOR DISHES	14.5"	(36.8 cm)
<b>ELECTRICAL RATING*</b>	<b>208 VOLTS</b> 1 PH—60 Hz	<b>230 VOLTS</b> 1 PH—60 Hz
	33 AMPS	35 AMPS
BOOSTER HEATER	5.3 kW	6.5 kW
WASH PUMP MOTOR	¾ HP	¾ HP
THIS SYSTEM REQUIRES THREE POWER WIRES, WHICH INCLUDES A CURRENT CARRYING NEUTRAL. AN ADDITIONAL FOURTH WIRE MUST BE PROVIDED FOR MACHINE GROUND.		
<b>SHIPPING WEIGHT</b>	234#	(106 kg)

\* For machines having "SAFETY TEMP" feature. \*\* For faster heat recovery.

## 1.2. CMA-180UC Operational Cycle

The CMA-180UC Operational Cycle has a total cycle time of 2 minutes (120 seconds). The Timing Diagram and the steps listed below detail the individual functions that are executed during each Operational Cycle.

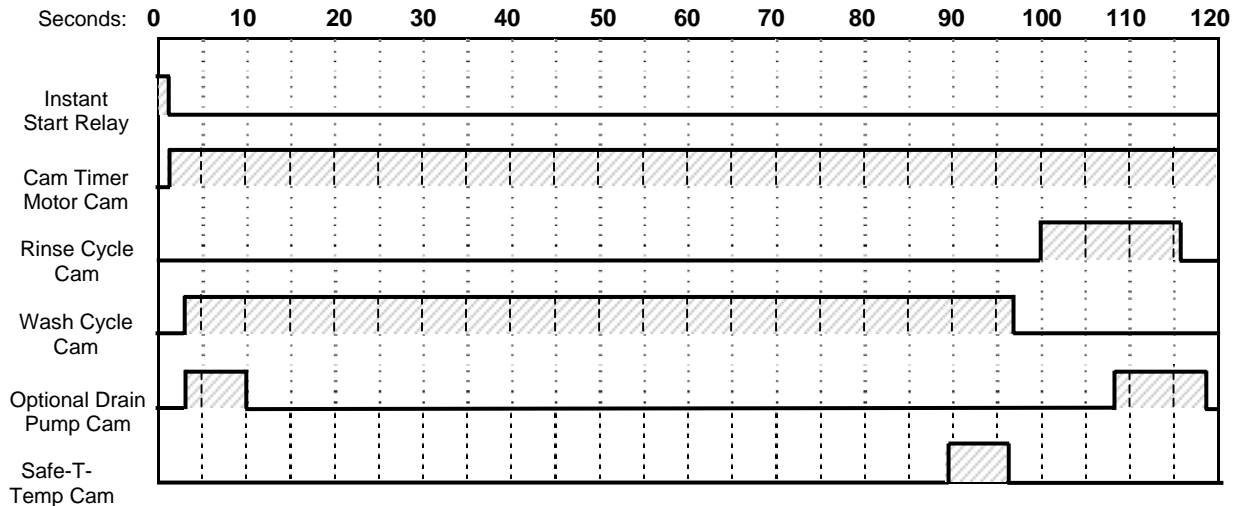

1. With the machine powered up toggling the START switch begins a cycle.
  - a) Toggling the START switch energizes both the Cam Timer motor and the Instant Start Relay. The Instant Start Relay latches ON the power to the Cam Timer motor so that the START switch can be released a moment after it has been toggled without the Cam Timer motor losing power.
  - b) After about 1.5 seconds the Cam Timer's first cam—the Cam Timer Motor Cam—latches ON the power to the Cam Timer motor and drops out the Instant Start Relay. The Cam Timer motor continues to run for a total of 2 minutes, at which time it switches OFF—resetting the Cam Timer—and waits for the next START command.
2. The Cam Timer's third cam controls the Wash Pump. The Wash Pump comes ON about 3 seconds into the Operational Cycle and continues to run for 94 seconds. This 94-second period is the Wash Cycle.
3. At the same time that the Wash Pump comes ON the Cam Timer's fourth cam powers ON the Optional Drain Pump—if one is present—and keeps it running for about 7 seconds before powering OFF. This cam turns ON again midway through the Rinse Cycle and stays ON for 10 seconds, turning OFF 2 seconds after the Rinse Cycle has completed.
4. About 3 seconds after the Wash Cycle has completed the Cam Timer's second cam, which controls the Rinse Cycle, turns ON—energizing the Water Solenoid—and stays ON for 16 seconds. This 16-second period is the Rinse Cycle.

5. When the cam timer assembly approaches the final rinse portion of the cycle, the “Safe-T-Temp” sixth micro switch will pause cam timer assembly if the booster heater has not reached 180 degrees. Machine will remain in wash cycle mode until 180-degree rinse temperature is reached, and at this time the cam timer will advance automatically into the rinse cycle and dispense 180 degrees rinse water over the dishes.



## 2. Getting Started

### 2.1. Introduction to CMA-180UC

The CMA-180UC is a hot water sanitizing, single rack, under-counter dishmachine. It is a standalone machine featuring a self-contained booster heater. The only external connections necessary are power supply, water supply, drainpipe, and optional chemical dispensers. The machine uses re-circulated wash water and fresh water final-rinse.

Operation of the CMA-180UC is extremely user friendly. To initially fill the machine each day, push the switch marked "FILL". The machine is full when water begins to flow into the scrap tray. The booster tank heater will maintain the wash water temperature at 155°F. The booster heater will produce a minimum of 180°F final rinse water each cycle.

The supply water to the CMA-180UC must be a minimum of 140°F at 24 PSI (Pounds per Square Inch) with a 6 GPM (Gallons Per Minute) flow rate and 60 GPH (Gallons Per Hour) recovery rate. The pipe supplying the water must be ½" minimum. The plumbing connection is located at the back of the machine. (See specification sheet on page 2).

The drain is a 1" barbed fitting on the back of the machine for easy attachment of your drain hose.

The machine retains the features of the standard CMA-180 Series in that it has a scrap tray and the manner in which the tank is filled ensures that the dishes are always rinsed with fresh water instead of re-circulated water. The CMA-180UC is the first under-counter dishmachine of its kind to discharge soil from the wash tank into a scrap tray outside of the wash chamber. This feature keeps the wash water much cleaner over long periods of time. The scrap tray may be emptied on a periodic basis without interruption of the flow of work, thereby providing a much cleaner environment for the wash and rinse cycle. There are also enhancements that can be chosen when required such as drain pump kits and other accessories. Refer to Section 4 "Parts" for the parts list and accessories available for the machine.

This manual is structured to provide a complete reference guide to the CMA-180UC. It is presented in a manner that all users will be able to comprehend and use as an effective tool in supporting the operation and maintenance of the dishmachine. The first section explains how the machine is packaged and what to look for when receiving the machine.

After unpacking the machine, this manual explains how to install and set up the machine for use. Requirements are given for plumbing, wiring, and space considerations. *These attributes of the machine are always taken into consideration by our well-trained sales representatives prior to the order being placed.* In the manual, guidance is also given for installation to ensure that the machine will be able to run at optimum conditions.

The Operation Section of the manual may be used for instruction and procedures when required. We make this portion of the manual easy to understand so that all levels of operators may be able to read and comprehend the operation of the machine. The function of the machine itself is mostly automatic and takes little training to put into full operation. The Operation Section also includes diagnostic considerations for the machine when problems occur.

The next section of the manual is the Parts. This section has the parts lists and wiring diagram for the machine.

We are committed to providing the best machines and customer service in the food industry and your feedback is welcome.

## **2.2. Receiving and Installation**

The dishwasher is shipped from the factory in a corrugated box on a wooden pallet. The installation guidelines give a systematic procedure for setting up the machine.

Start by removing the packaging material. Unwrap the machine and check for the following component parts:

The Wash Tank Scrap Screen is shipped inside the wash cavity of the machine. This screen must be in place during operation. It has been designed to perform two basic functions:

1. Strain water that is circulating through the spray arms and pump assembly.
2. A basket to catch broken glass, or heavy solids that may plug the impeller.

Set the machine in place, and level from side-to-side and front-to-back.

### **2.2.1. Electrical<sup>1</sup>**

A 50-amp, single-phase 230 volt, 60 Hz dedicated circuit should be used to supply electrical energy to the CMA-180UC dishwasher (see specification sheet page 2). This system requires three power wires, which include a current carrying neutral. An additional fourth wire must be provided for ground. CMA and local codes require the CMA-180UC to be hardwired using #8 AWG (90°C) copper wire (minimum). Approximately 4-feet of ¾" flexible conduit with power leads (L-1, L-2, Neutral and Ground) extending out of the conduit are provided for easily connecting the power at installation. The power connection must be located such that there is sufficient length of the flexible conduit remaining to permit the machine to be moved for cleaning.

### **2.2.2. Plumbing<sup>2</sup>**

The machine is equipped with a ½" NPT connection located at the lower left-hand corner (facing the back) of the machine. A 140°F water line should be plumbed to this point (see specification sheet page 2). The water line used must be of sufficient length and flexibility to permit the machine to be moved for cleaning.

**Important:** New machines equipped with Dema Valve and Dema Flow Disc requires an unrestricted water supply line minimum of ½".

The supply water to the CMA-180UC must be a minimum of 140°F at 24 PSI (Pounds per Square Inch) with a 6 GPM (Gallons Per Minute) flow rate and 60 GPH (Gallons Per Hour) recovery rate. The pipe supplying the water must be ½" minimum. The plumbing connection is located at the back of the machine. (See specification sheet on page 2).

The CMA-180UC may be supplied with an optional drain pump for elevated drains. For floor gravity drain applications the drain pump should not be used and a good commercial grade hose needs to be connected to the discharge side of the diverter valve (drain valve) and run to the floor drain. If removing a drain pump, safe-end (insulate electrically) the white and purple wires and secure them out of the way. If a drain pump is used with a floor drain, the drain hose must rise 12 to 16" before dropping to the floor drain (to reduce any chance of the pump cavitations).

**Warning:** If the water hardness is greater than 3 grains per gallon, a water softener is required to prevent damage to heating elements (scale build- up) and booster tank rinse flow restriction. Rinse flow restriction will cause the booster tank to expand and contract causing metal flex, which will eventually crack the tank.

---

<sup>1,2</sup>**All electrical and plumbing connections must be made by a qualified person who will comply with all available Federal, State, and Local Health, Electrical, Plumbing and Safety codes**

### 2.2.3. BETA Detergent And Rinse Dispenser (Optional).

Optional built-in Beta dispenser (CMA p/n 14585.00) has easy access for chemical settings behind the front kick panel. Both initial charge and recharge are factory pre-set. Basic settings for both detergent and rinse speed are 50%. Operating fine-adjustment screws on the dispenser can control the amount of chemicals drawn into chemical lines.

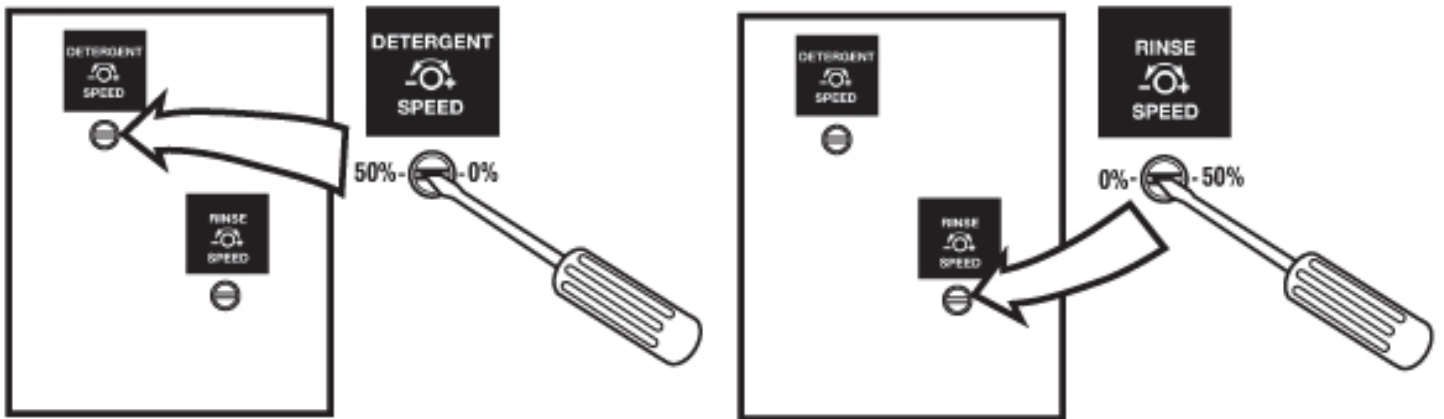

Undercounter machine with the optional dispenser must be ordered separately, as option at time of order. Optional dispenser has to be pre-wired prior to shipment (see electrical diagram for wiring options).

## 2.2.4. NOVA Detergent and Rinse Dispenser (Optional)<sup>1</sup>.

The NOVA Detergent and Rinse Dispenser has its own reference manual. Familiarize yourself with the dispenser's reference manual before proceeding with installation.

1. The NOVA dispenser is pre-wired with a multi-conductor electrical cable that is to be run through a conduit to the power block inside the control panel drawer. Use a ½" watertight conduit meeting all local and national codes. A conduit fitting is present on the bottom of the dispenser where the power cable exits. A mounting plate to receive the ½" conduit is provided on the top right-hand corner (facing the back) of the machine.
  - i. Run an appropriate length of ½" conduit from your dispenser to the mounting plate where it will be secured. The conduit needs to be of sufficient length and flexibility to permit the machine to be moved for cleaning without having to disconnect any wiring.
  - ii. Run your dispenser wires through the conduit and through the enclosed area across the top of the machine and then feed them through the access hole provided in the back of the control panel drawer.
  - iii. With the machine's power "OFF", connect your detergent and rinse dispenser wires to the power block supplied and labeled ("DISPENSER 110V - 3 AMPS MAX") inside the control panel drawer. The table that follows lists the function of each conductor of the multi-conductor electrical cable.

Wire Colors	Circuit Voltage	Function
Gray/Violet	90 VAC-130 VAC 50/60 Hz	Main AC Power
Black	90 VAC-130 VAC 50/60 Hz	Main AC Power
Brown	No Connection. <b>Insulate this wire!</b>	This wire is LIVE!
Yellow	90 VAC-130 VAC 50/60 Hz	Detergent Signal
White/Yellow	90 VAC-130 VAC 50/60 Hz	Detergent Signal
Violet	90 VAC -130 VAC 50/60 Hz	Rinse Signal
White/Violet	90 VAC -130 VAC 50/60 Hz	Rinse Signal

The individual conductors need to be connected as shown in Figure 2.2.4 and as described on next page.

---

<sup>1</sup> All electrical and plumbing connections must be made by a qualified person who will comply with all available Federal, State, and Local Health, Electrical, Plumbing and Safety codes

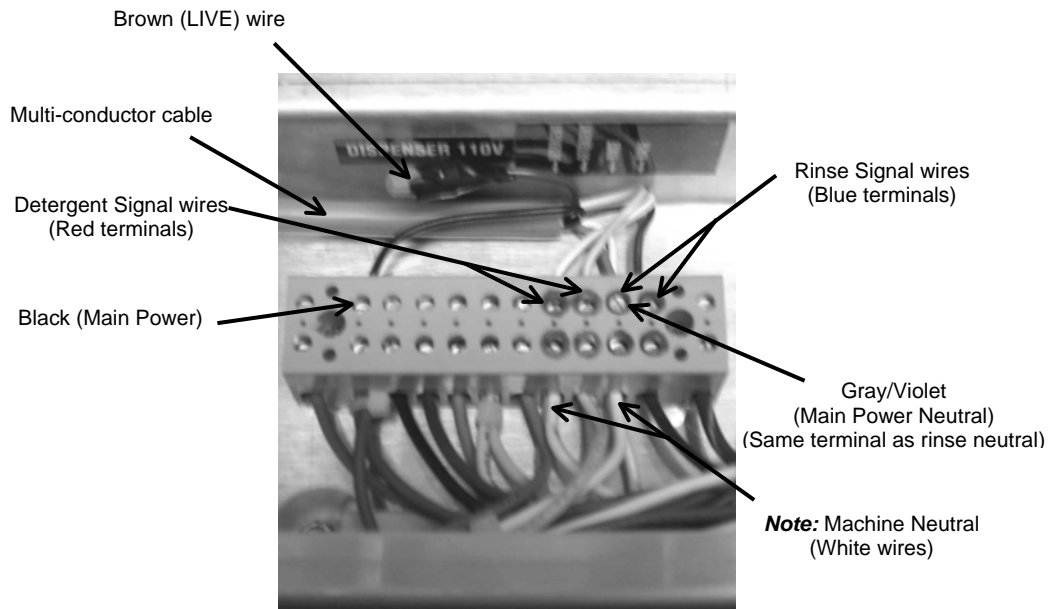

**Figure 2.2.4**

**Note:** In Figure 2.2.4 the machine's wire harness was left out of the back of the power block to more clearly show the dispenser wires.

2. Remove the plug from the mixing chamber located by the vacuum breaker on the back of machine; and install the rinse injection fitting (supplied with your dispenser). See Figure 2.2.4.

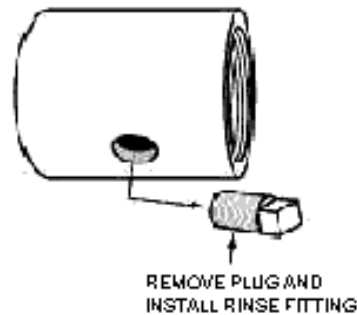

**Figure 2.2.4.**

3. A 7/8" detergent injection hole is provided in the back of the wash tank. Remove the S.S. plug and install the detergent fitting (supplied with your dispenser).
4. The final step of installing the CMA supplied Detergent and Rinse Dispenser is programming it to your specific application. The reference manual supplied with the dispenser shows you how to program it.
  - Keep in mind while reading the reference manual that the CMA-180UC operates in "probe-less" mode. (This mode is selected by setting a value of "2" in screen 21).
  - Screen 22 must be set to "1" (Door).

## 2.2.5. Safe Ttemp Feature

The CMA “SafeTemp” feature assures the final rinse cycle is always at a consistent minimum of 180 degrees.

**How it works:** the “SafeTemp” function operates off the 5<sup>th</sup> cam (labeled “SafeTemp”) on the timer assembly. When the cam timer assembly completes the wash cycle, and approaches the final rinse portion of the cycle, the “SafeTemp” micro switch will drop into the cam slot and pause cam timer assembly if the booster heater has not reached 180 degrees. Machine will remain in wash cycle mode until 180 degree rinse temperature is met, and at this time the cam timer will advance automatically into the rinse cycle and dispense 180 degrees rinse water over the dishes.

**Note:** if Safe Ttemp cam is not to be used, it becomes a spare cam.

### **CMA -180“SafeTemp” Installation Instructions:**

- 1) Remove the 4cam timer assembly (note wire colors and wire placement for all 4cam timer micro switches) and install 5cam timer in its place.
- 2) Place all wires removed from 4cam timer assembly in exact position on 5cam timer assembly.
- 3) The cam timer motor receives (1) yellow wire and (1) white wire (re-connect the yellow wire only from dishmachine harness to the motor).
- 4) The “SafeTemp” 5 cam timer assembly kit includes a two white harness – connect white wire with female bullet connector to the timer motor, stripped end to #22/NC on contactor, and spade end to center terminal 5<sup>th</sup> micro switch.
- 5) Connect white wire with male bullet connector from the kit to the white wire with female bullet connector coming from dishmachine harness, stripped end to #21/NC on contactor, and spade end to top terminal on 5<sup>th</sup> micro switch.

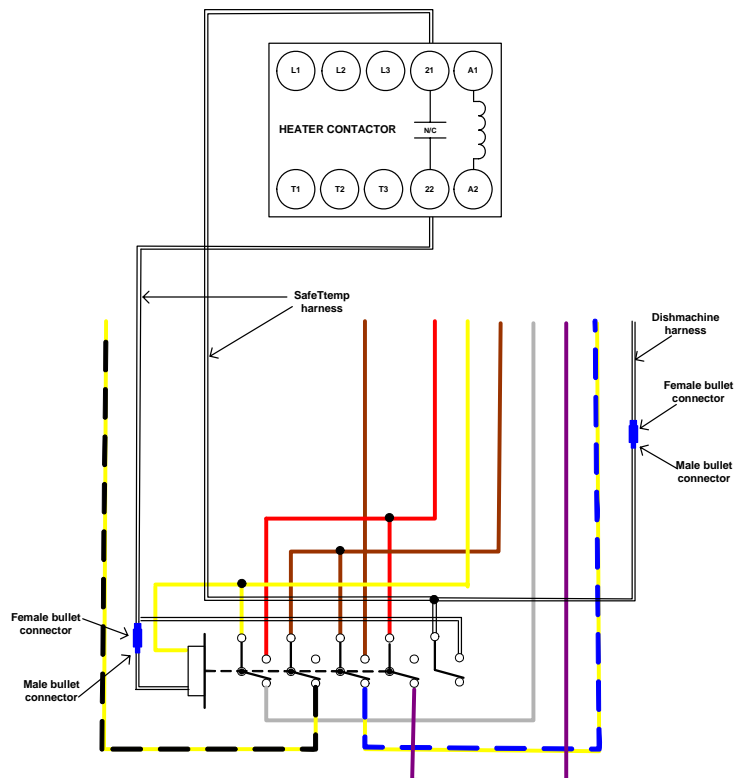

## 2.2.6. Water Tempering Kit

# 180UC Water Tempering Valve Kit

P/N 13470.50

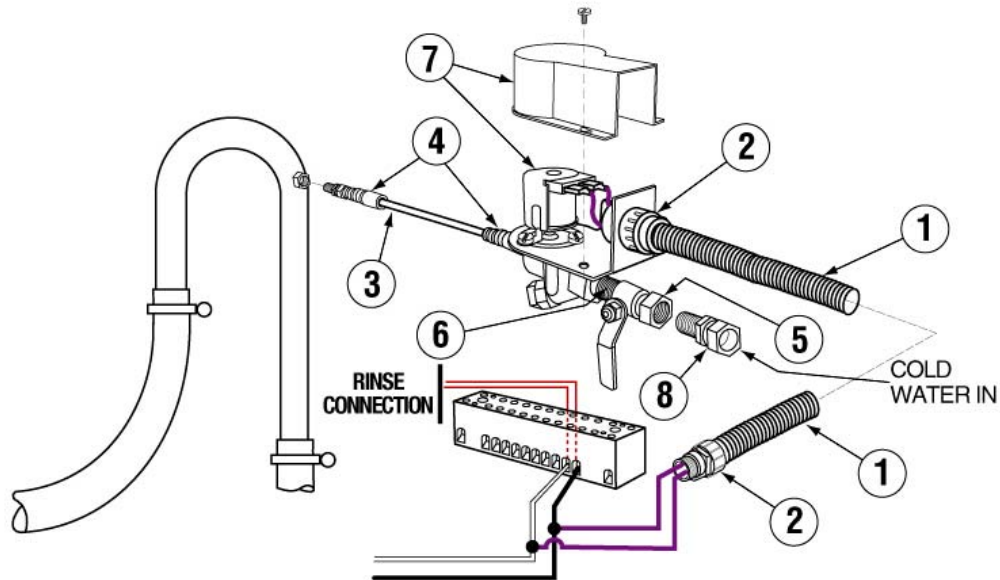

### INSTALLATION INSTRUCTIONS TO DRAIN TEMPERING KIT

**NOTE:** Turn the dishwasher's wall breaker to "OFF" position before this installation.

1. Undo the drain hose clamp connecting the drain line gooseneck to drain hose leading to floor drain.
2. Install the water junction tee as shown on drain line gooseneck and tighten clamp.
3. Connect the drain hose to lower port of water injection tee and tighten hose clamp.
4. Insert the provided white chemical tube into compression nut of water injection tee and tighten compression nut.
5. Connect the provided cold-water solenoid's power leads to the rinse (yellow and white) terminals in dishwasher's terminal block.
6. Connect the water injection assembly's ball valve to a cold water supply.
7. Run the dishwasher through a few cycles and make sure the cold water is injected and check for any possible leaks.

ITEM NO.	P/N	NO REQ'D	DESCRIPTION
1.	00400.00	2	CONDUIT 3/8" SEALTITE
2.	00401.00	2	ST-3/8" STRAIGHT CONNECTOR
3.	00425.54	6	CHEMICAL TUBING WHITE
4.	03415.50	2	FLEX-TIGHT FITTING
5.	41010.00	1	1/4" MIP BALL VALVE
6.	41011.00	1	NIPPLE BRASS 1/4" CLOSE
7.	41015.05	1	SOLENOID VALVE 1/4" W/COVER 220V
8.	40116.00	1	1/4" COMP X 1/4" MIPFTG

### **2.2.7. Booster Heater Setup**

The booster tank must be filled with water before the heating element is energized. For this reason the "High Limit Switch" has intentionally been disconnected at the factory and will require re-connection before the heating element will turn on.

Follow the procedure below to complete the initial installation:

1. Close the door on the machine.
2. Turn the Power switch to the "ON" position.
3. Hold the "FILL" switch in until water overflows into the scrap tray.
4. Turn the Power switch to the "OFF" position.
5. Connect blue wire with disconnect, identified by red tag, to the High Limit Switch which is located behind the thermostat behind the front kick panel.

### **2.2.8. Installers Checklist**

- Dishmachine checked for concealed damage
- Hot water supply is 140° F (60 C) — minimum
- Incoming water supply line is ½" — minimum
- Incoming water supply is 6 GPM minimum at 24 PSI
- Supply circuit breaker for machine is properly sized (50 amp)
- Service voltage and phase type are correct to machine data plate
- If drain pump is used, drain hose rises 12 to 16" before dropping to drain
- Drain hose is installed with air gap (discharge 1" above drain)
- Optional detergent and rinse dispenser (if present) is properly installed
- Dishmachine is properly grounded
- Dishmachine is properly leveled
- Machine circuit breaker is labeled "DISHWASHER"
- Machine has been "hard-wired" with correctly sized wire
- Booster tank has been filled with water (before High Limit Switch is reset)
- High Limit Switch for heater has been reset (after Booster Tank has been filled)

---

## 3. Operation

---

### 3.1. *Initial Setup*

#### 3.1.1. Dema Valve and Dema Flow Disc (New Models).

New Dema Valve made of stainless steel is more compatible with various water conditions. Dema Flow Disc has been placed on the exit side of the water valve. The Flow Disc reduces pressure to the standard recommended 20 PSI.

#### 3.1.2. Rinse Pressure Regulator (Old Models Prior January 2008).

The CMA-180UC requires a supply water input pressure of 24 PSI minimum. This pressure is then reduced by the supply water regulator. Use the following procedure to adjust the rinse pressure to 20 PSI:

1. Close the door on the machine.
2. Turn the Power switch to the "ON" position.
3. While holding the "FILL" switch—to activate the water solenoid—adjust the pressure regulator until the gauge reads 20 PSI. (Regulator is located behind the front kick panel).

#### 3.1.3. Rinse and Wash Temperatures

1. Turn the Power switch to the "ON" position.
2. After the machine has warmed up for about ten-minutes, note the wash and rinse temperatures. The wash temperature must be 155°F minimum. The rinse temperature must be 180°F minimum<sup>3</sup>. If necessary, adjust the temperatures by removing the front kick panel and turning the thermostat adjustment clockwise to increase, counterclockwise to decrease. This one adjustment controls both temperatures.

#### 3.1.4. Post Instructions

1. Install wall chart and instruct machine operator on proper cleaning and operation of the CMA-180UC.

### 3.2. *Startup Procedures*

1. Open the door of the machine and check that the scrap screen is in place, and that the spray arms and end plugs are secure.
2. Close the door of the machine and turn the Power switch to the "ON" position.
3. Hold the fill button about 25 seconds or until the water overflows into the scrap tray.
4. Once the water is filled to the proper level, press the rocker switch marked "START" – the machine will automatically begin its cycle.
5. Check machine's operating temperatures — Adjust if necessary. See section 3.1.3 Rinse and Wash Temperatures.
6. At the end of the wash period, drain the machine by pushing the rocker switch marked "DRAIN". Clean the wash tank screen and scrap tray screen. Remove and clean the spray arms. (See wall chart instructions).

---

<sup>3</sup> Rinse cycle temperature must be observed during a rinse cycle while the machine is in operation.

3.3. *Operating and Cleaning Instructions*



# Operating and Cleaning Instructions

## CMA-180UC Undercounter Dishmachine

**1** Open dishmachine door, verify internal scrap screen is in place, then load dish rack.

**2** If dishmachine requires powdered soap installed by hand, add proper amount for one (1) gallon of water based on soap manufacturer's recommendations. **IF USING AUTOMATICALLY INJECTED LIQUID SOAP, SKIP THIS STEP.**

**3** Close dishmachine door.

**4** Turn power switch to "ON" position.

**5** Hold the fill button until the water overflows into the external scrap drawer. (Initial fill only.)

**6** Once proper water level is attained and wash temperature reaches 150°F press rocker switch marked "START".

**7** After completion of the wash & rinse cycle, open door, remove clean rack of dishes, load next rack of soiled dishes, close door, press rocker switch marked "START". Repeat as needed.

**8** After all racks of dishes are washed, press and hold rocker switch marked "DRAIN" to drain the wash tank.

**9** Open door. Remove and clean internal scrap screen.

**10** Remove and clean external scrap drawer.

## MAINTENANCE:

**1** Periodically, inspect before operating:

- Open door and verify internal scrap screen is secure and in place.
- Verify each spray arm is properly installed and threaded assembly is tight.
- Verify spray arm end plugs are tight and secure.

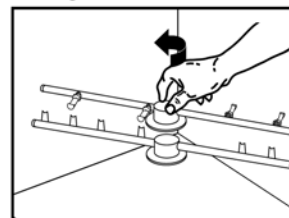

**2** Periodically, remove top and bottom spray arms. Next, inspect spray jets and clean as needed.

- Remove spray arm end plugs and flush with water.

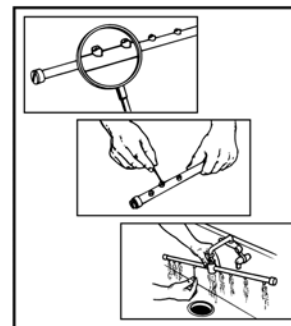

3.4. Preventive Maintenance Chart



**PREVENTIVE MAINTENANCE FOR MODEL CMA-180UC**



**1** If rinse arm jets are clogged, remove rinse arm (by turning bearing counter clockwise) and clean out rinse jets with paper clip or small pointed object.

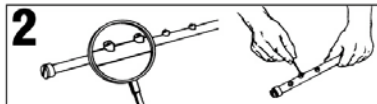

**2** Inspect top and bottom spray arms daily. Use toothpick to push debris into spray arm. Remove end plugs and flush with water.

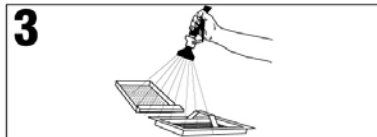

**3** Remove and thoroughly clean scrap tray, and scrap drawer daily.

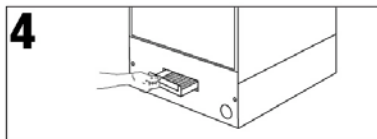

**4** Replace screens after cleaning.

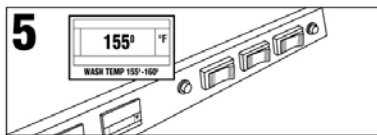

**5** Confirm wash temperature is 155°F.

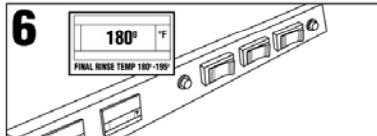

**6** Check rinse temperature minimum 180°F. Notify supervisor if rinse temperature is below 180°F.

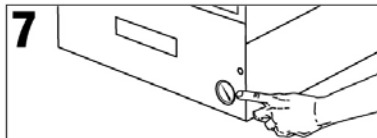

**7** Check rinse pressure 15-22 psi.



**8** Check chemical containers for product. Confirm correct product line is in the bucket.  
**RED - Detergent**  
**BLUE - Rinse Aid**



**9** Check machine for leaks.

### 3.5. Quick service guide

MODEL: CMA 180UC HIGH TEMP UNDER COUNTER

TECHNICAL ISSUE	CAUSE	SOLUTION
Scrap trap over flows	Pressure regulator is not set properly	Set regulator to 18-20 psi
	Faulty rinse micro switch	Replace micro switch, P/N 00411.00
	Drain hose elevated too high	Must be lowered to goose neck level
	Obstruction in drain hose	Check hose & clean
	Scrap exit screen	Clean exit screen
	Faulty drain pump	Replace pump, P/N 15503.00
Door leaks	Machine not level	Adjust machine legs to level
	Machine is leaning forward	Adjust machine legs to level
	Wash arm end cap missing	Replace end cap, P/N 00308.20
	Door gasket	Replace gasket, P/N 14506.60
Thermometer failure	Loose wire at display, board or transformer	Secure connectors
	Faulty temperature sensing wire	Correct, replace, P/N 03202.66
	Faulty temperature sensing unit	Replace unit, P/N 03203.00
	Faulty transformer	Replace transformer, P/N 03202.60
Rinse water temperature low /high	Scaled heating element	Clean scale from heater
	Booster heater's thermostat not properly set	Adjust thermostat
	Incoming water temperature to booster heater below 140 F	Adjust external water heater in the facility
Pump motor not running	Loose lead connections	Check and crimp connectors
	Faulty # 3 micro switch	Replace micro switch, P/N 00411.00
	Faulty contactor	Replace contactor, P/N 15504.00
	Faulty wash pump motor	Replace wash pump motor, P/N 00201.00
Pump motor runs continuously	Faulty # 3 micro switch	Replace micro switch, P/N 00411.00
	Faulty contactor	Replace contactor, P/N015504.00
Low water pressure at the final rinse	Water regulator not adjusted properly	Adjust regulator to 18-20 PSI
	Clogged final rinse spray jets	Clean jets
	Missing final rinse spray end cap	Replace end cap, P/N 00308.17
	Low incoming water pressure from facility	Increase pressure to 18-20 psi
Scrap trap overflows over night	Faulty water solenoid diaphragm	Clean or replace diaphragm, P/N 00706.00
Poor cleaning results	Low wash or rinse water temp.	Check temperature settings
	Wash arm bearing or jets	Clean bearing and arm jets
	Rinse arm bearing or jets	Clean bearing and arm jets
Wash tank will not drain.	Tank discharge screen dirty	Clean screen
	Drain valve not operating	Check power to drain valve
	Drain valve faulty	Replace Drain valve, P/N 04103.00

### 3.6. Troubleshooting

PROBLEM	LIKELY CAUSE	SOLUTION
Machine inoperative	Power off at circuit breaker	Reset circuit breaker
	Defective power switch	Replace power switch P/N: <u>15521.50</u>
Motor inoperative	Door is open	Close door
	Control panel is pulled out	Secure control panel
	Defective reed switch	Replace reed switch P/N: <u>00557.55</u>
	Defective timer assembly	Replace timer assembly* P/N: <u>14408.80</u>
	Defective pump motor contactor	Replace contactor P/N: <u>15504.00</u>
	Defective motor	Replace motor P/N: <u>00201.66</u>
Motor runs with door open	Defective reed switch	Replace reed switch P/N: <u>00557.55</u>
	Defective pump motor contactor	Replace contactor P/N: <u>15504.00</u>
Heater (no heat)	High limit switch opened or defective	Reset or replace switch P/N: <u>17523.51</u>
	Defective thermostat	Replace thermostat P/N: <u>13417.89</u>
	Defective heater contactor	Replace heater contactor P/N: <u>15504.50</u>
	Defective heater	Replace heater P/N: <u>15517.00</u>
Heater (never turns off)	Defective thermostat	Replace thermostat P/N: <u>13417.89</u>
	Defective heater contactor	Replace heater contactor P/N: <u>15504.50</u>

\*The timer assembly motor (P/N: 00501.00) or micro switches (P/N: 00411.00) can be replaced independently if that's the only component that's failed.

PROBLEM	LIKELY CAUSE	SOLUTION
Low heat during operation	Low incoming water temperature (below 140° F)	Turn up supply water heater Insulate supply water pipe
	Thermostat out of adjustment	Adjust thermostat
	Cold water mixing with supply	Isolate hot water from cold water
	Defective heater	Replace heater <b>P/N: <u>15517.00</u></b>
Low rinse water pressure	Pressure regulator out of adjustment	Adjust pressure regulator
	Defective pressure gauge (actual pressure is okay)	Replace pressure gauge <b>P/N: <u>13605.45</u></b>
Regulator at maximum but rinse pressure still low	Insufficient water supply flow	Supply larger supply line
	Defective water solenoid valve	Replace water solenoid valve <b>P/N: <u>03603.10</u></b>
Low rinse water flow	Low rinse water pressure	See "Low rinse water pressure" in <b>PROBLEM</b> column
	Limed up rinse arm spray nozzles	De-lime rinse arm nozzles
No rinse water flow	Defective water solenoid valve	Replace water solenoid valve <b>P/N: <u>03603.10</u></b>
	Defective (Rinse Relay) ice cube relay	Replace ice cube relay <b>P/N: <u>00631.00</u></b>
Rinse water runs with door open	Defective reed switch	Replace reed switch <b>P/N: <u>00557.55</u></b>
Water overflows scrap tray onto floor	Drain hose is kinked	Un-kink drain hose
	Drain hose is not properly elevated before dropping to drain (if drain pump is used)	Elevate drain hose 12 to 16" above pump before dropping to drain
	Defective timer assembly	Replace timer assembly* <b>P/N: <u>14408.80</u></b>
	Defective drain pump (if drain pump is used)	Replace drain pump <b>P/N: <u>15503.00</u></b>
With power on, activating start switch does not begin cycle	Defective start switch (cycle light will not light either)	Replace start switch <b>P/N: <u>15521.00</u></b>
	Defective timer assembly	Replace timer assembly* <b>P/N: <u>14408.80</u></b>

\*The timer assembly motor (P/N: 00501.00) or micro switches (P/N: 00411.00) can be replaced independently if that's the only component that's failed.

PROBLEM	LIKELY CAUSE	SOLUTION
Start switch requires > 1 second activation to run cycle	Defective (Instant Start) ice cube relay	Replace ice cube relay P/N: <u>00631.00</u>
Activating fill switch does not fill machine	Defective drain/fill switch	Replace drain/fill switch P/N: <u>15522.00</u>
	Defective water solenoid valve	Replace water solenoid valve P/N: <u>03603.10</u>
Fill (rinse water) won't shut off	Defective water solenoid valve	Replace water solenoid valve P/N: <u>03603.10</u>
	Defective drain/fill switch	Replace drain/fill switch P/N: <u>15522.00</u>
	Defective timer assembly	Replace timer assembly* P/N: <u>14408.80</u>
	Defective (Rinse Relay) ice cube relay	Replace ice cube relay P/N: <u>00631.00</u>
Activating drain switch does not drain machine	Drain hose is kinked	Un-kink drain hose
	Defective drain/fill switch	Replace drain/fill switch P/N: <u>15522.00</u>
	Defective drain valve	Replace drain valve P/N: <u>04103.00</u>
Cycle light does not light while cycle runs	Defective cycle light	Replace cycle light (green) P/N: <u>00406.60</u>
Power light does not light but machine runs	Defective power light	Replace power light (red) P/N: <u>00406.00</u>
Wash tank or final rinse temperature does not display	Defective digital thermometer	Replace digital thermometer P/N: <u>03202.45</u>
Both the wash tank temperature and the final rinse temperature do not display	Defective thermometer transformer	Replace thermometer transformer P/N: <u>03202.60</u>
Wash tank or final rinse displays wrong temperature	Defective digital thermometer	Replace digital thermometer P/N: <u>03202.45</u>
	Defective thermister	Replace thermister P/N: <u>03202.65</u>

\*The timer assembly motor (P/N: 00501.00) or micro switches (P/N: 00411.00) can be replaced independently if that's the only component that's failed.



## 4. Parts Kit

### 4.1. Initial Parts Kit (P/N 1100.66)

P/N	DESCRIPTION	Qty
15504.00	Motor Contactor, 2-Pole 20 Amp	1
15504.50	Heater Contactor, 2-Pole 35 Amp	1
00501.00	2-Minute Timer Motor	1
00631.00	Ice Cube Relay 120 V	1
15521.00	Rocker Switch Start Momentary	1
15522.00	Rocker Switch Drain/Fill	1
15521.50	Rocker Switch Power Maintained	1
00557.55	Reed Switch	1
03623.00	1/2" Vacuum Breaker Repair Kit – Watts	1
00707.00	1/2" Water Solenoid Repair Kit – J/E	1
04103.00	L1X/L1-C Drain Valve 120V	1
00206.00	Pump Seal Kit	1
13417.89	Heater Thermostat	1
17523.60	High Limit Switch 200°F	1
00411.00	Microswitch	1
00738.15	3/4" Water Solenoid Valve Coil – J/E	1

**4.2. Optional Drain Pump Kit**

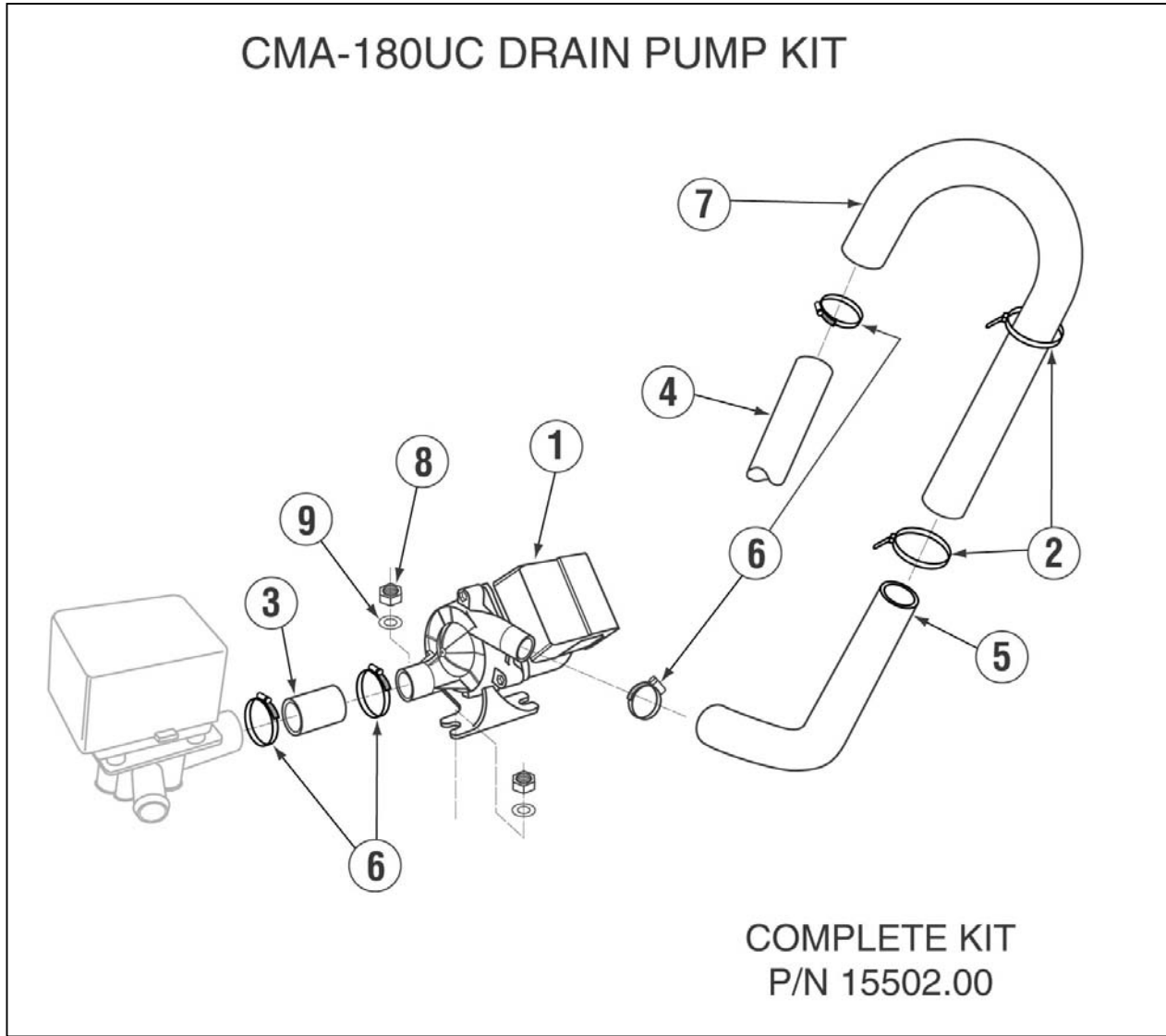

ITEM NO.	NO. REQ'D	P/N	DESCRIPTION
1	1	15503.00	Drain Motor Ultra Jet for CMA-180UC
2	2	00432.50	Twist Tie
3	1	15601.10	Black Drain Hose 1" ID X 3 1/2"
4	1	15601.50	Drain Hose 1" ID, 6 ft
5	1	15601.60	Robber Hose 90 Deg.

ITEM NO.	NO. REQ'D	P/N	DESCRIPTION
6	4	03101.00	Hose Clamp 1"
7	1	15603.00	Drain Line Gooseneck
8	2	03801.10	10-32 SS Nut
9	2	04806.00	#10 Brass Washer

### 4.3. Optional Drain Pump—INSTALLATION INSTRUCTIONS

1. Start by removing the existing drain hose from the Drain Valve as shown in **Figure 1**.

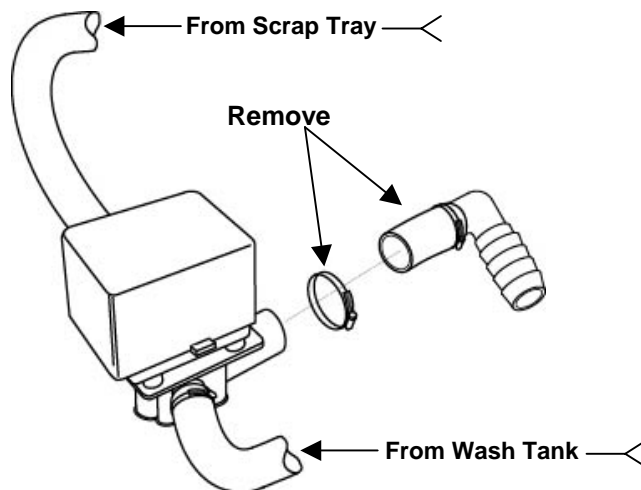

Figure 1

2. Locate the white and purple wires that are safe-ended and tie-wrapped at the top of the Drain Pump compartment. Bring these wires out so they can be connected after mounting the Drain Pump.
3. Connect the 3-inch long pump inlet drain hose to the Drain Valve and mount the Drain Pump using the nuts and washers provided with the kit as shown in **Figure 2**.

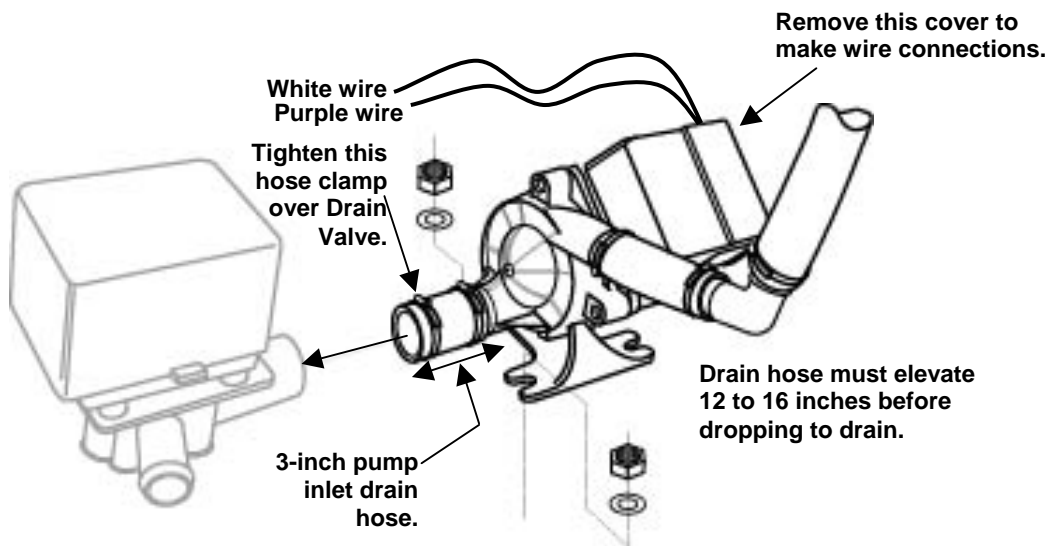
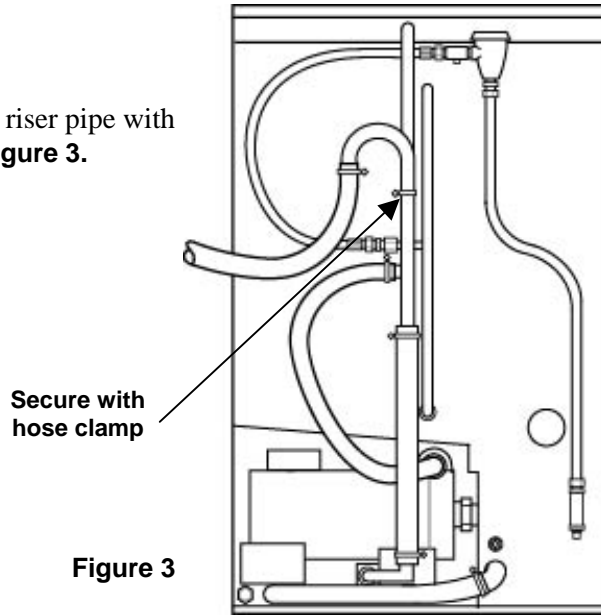

Figure 2

4. Remove the terminal cover and connect the white and purple wires to the two white wires from the pump. Replace the cover.

5. Secure the drain gooseneck to the wash riser pipe with the hose clamp provided as shown in **Figure 3**.



6. Route the drain hose to the drain and provide a 1-inch air gap at the drain.

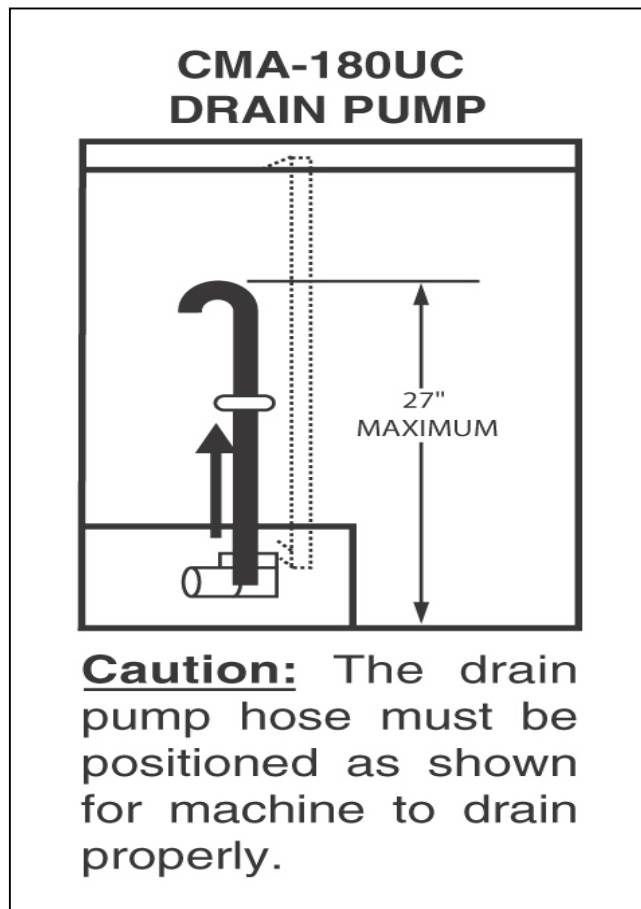



## 5. Customer Notice

---

# CMA-180UC Installation Guidelines

Improper installation of this product may void the warranty on this machine. Please follow these guidelines for recommended installation and to ensure the warranty of this model is authorized by CMA Dishmachines.

### Dishmachine Installation Requirements

1. Machine **must** be level. Adjust leveling feet to accommodate uneven floor surfaces.
2. Drain height should not exceed maximum height of 16". If there is a floor drain, it is highly recommended the pump drain be removed. Connect supplied drain line to 3-way valve on back of machine and gravity feed to the floor drain.
3. PRV must be adjusted not to exceed 20 psi. Recommended pressure is between 18-20 psi.
4. Water supply to machine must be a minimum 120°F for 3 minute cycle models and 140°F for 2 minute cycle models.
5. A four-wire, (neutral, ground and two 110v lines) 220v single phase connection is required. There is a six foot cord provided with the machine. CMA recommends a minimum 50-amp dedicated circuit, but you should consult your local building code requirements for proper breaker size.

### Activating/Adjusting the Booster Heater

1. Booster heater **must** be filled with water prior to connecting the blue wire from high limit switch. The high limit switch can be found by removing the front panel and locating the red button on the front of the heater tank.
2. Once the booster has been connected, the thermostat should be adjusted to maintain 180°F during the final rinse cycle. The thermostat is located on the front of the booster tank and is accessible by removing the front panel on the machine.

### Automatic Dispensing Equipment

1. Applications utilizing automated dispensers for administering warewash chemicals must use 110v dispenser equipment. There is a 110v power block for installing this equipment inside the control panel.

## 6. Electrical Diagram

### CMA-180UC ELECTRICAL DIAGRAM CONTROL PANEL

Rev.2-5-09

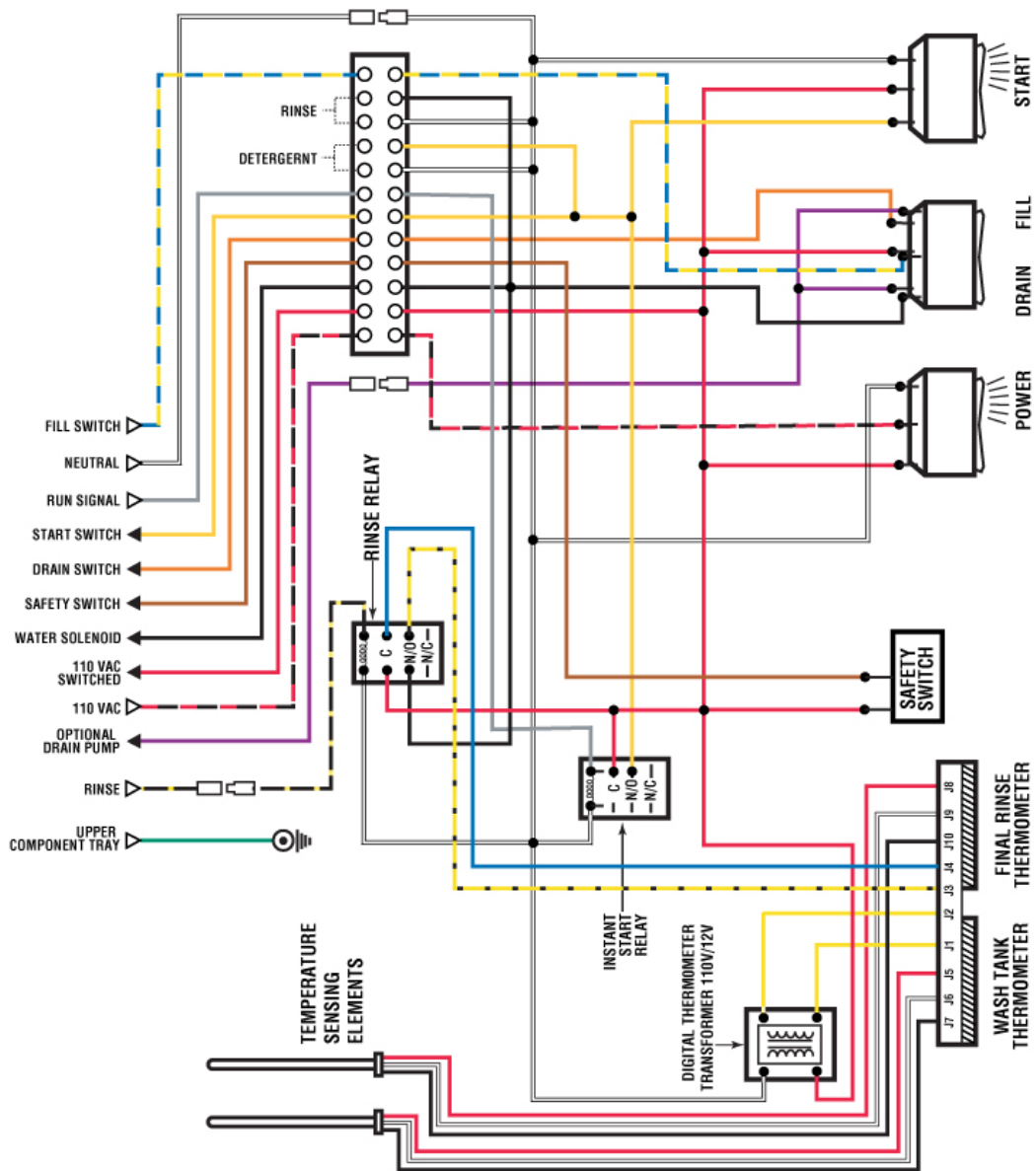

# CMA-180UC ELECTRICAL DIAGRAM POWER BOX

