



MODEL CMA-180

PARTS MANUAL

Rev 2.07



CMA DISHMACHINES
12700 KNOTT AVENUE
GARDEN GROVE, CALIFORNIA 92841
800-854-6417
FAX 714-895-2141

www.cmadishmachines.com



TABLE OF CONTENTS

MODEL CMA-180

1. PARTS MANUAL	3
1.1. EXPLODED VIEW DRAWINGS.....	3
1.1.1 Straight Frame System Assembly.....	3
1.1.2 Corner Frame Assembly.....	4
1.1.3 Drain System Assembly.....	5
1.1.4 Plumbing System Assembly.....	6
1.1.5 Wash Spray System.....	7
1.1.6 Final Rinse System.....	8
1.1.7 Door Handle Assembly.....	9
1.1.8 Corner Door Handle Assembly	10
1.1.9 Pump System Assembly.....	11
1.1.10 Old Wash Tank Heater (Square Flange).....	12
1.1.11 Old Booster Heater (Square Flange).....	13
1.1.12 New Wash Tank Heater (Triangular Flange).....	14
1.1.13 New Booster Heater (Triangular Flange).....	15
1.1.14 Wiring Harnesses	16
1.1.15 480V Control Box Assembly p/n 18611.48 (480V machines only)	17
1.1.16 Control Box Assembly	18
1.2. Unique Parts For CMA-180TS.....	19
1.3. Unique Parts For CMA-180TC	20
2. POWER SWITCH BULB REPLACEMENT INSTRUCTIONS.....	21
3. 180 CONVERSION KIT – CORNER TO STRAIGHT #00617.18.....	22
4. 180 CONVERSION KIT – STRAIGHT TO CORNER #00617.17.....	23

1. Parts Manual

1.1. Exploded View Drawings

1.1.1 Straight Frame System Assembly

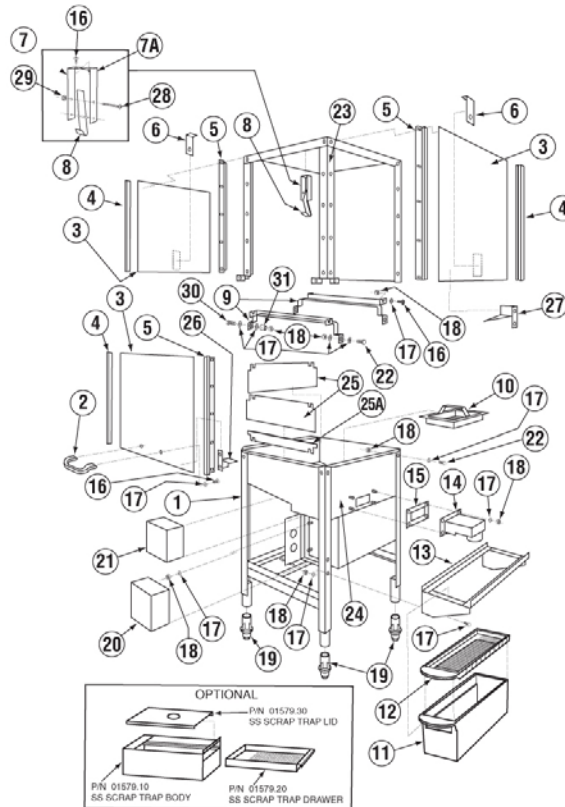

ITEM NO.	NO. REQ'D	P/N	DESCRIPTION
1	1	17532.00	Stand
2	1	00535.30	Front door Handle
3	3	17506.00	Door
4	6	00636.17	E Z Door Glide
5	6	17554.00	Door Guide
6	2	17552.00	Door Stop
7	1	13915.00	Door Latch Bracket
7A	1	13915.06	Door Latch Bracket
8	1	13701.00	Open Door Latch
9	1	01505.02	Tray Track (Set)
10	2	17510.00	Strainer Basket
11	1	01577.10	Scrap Tray Body
12	1	01577.20	Scrap Trap Drawer
13	1	17579.00	Scrap Trap Holder
14	1	17511.00	Overflow
15	1	17402.00	Overflow Gasket
16	30	00905.00	1/4-20 x 1/2 Trus Bolt

ITEM NO.	NO. REQ'D	P/N	DESCRIPTION
17	60	00924.00	1/4" SS Washer
18	30	00912.00	1/4"-20 Nylon Lock Nut
19	4	01310.00	Bullet Feet
20	1	17522.50	Wash Tank Heater Cover
21	1	17522.00	Booster Heater Cover
22	23	00914.10	1/4-20 X 5/8 Hex Bolt
23	1	17530.00	Wrapper
24	1	17531.00	Pan
25	2	17506.60	Door Panel Splash Guard
25A	1	17506.65	Door Service Splash Guard
26	1	17506.21	Front Door Safety Bracket
27	1	17506.32	Right Door Safety Bracket
28	1	00960.00	8-32x1-1/2"pPanhead Screw
29	1	00927.00	8-32 Nylon Lock Nut
30	2	00962.00	1/4-20 X 1 SS Hex Bolt
31	4	00610.00	Door Handle Spacer (Small)

1.1.2 Corner Frame Assembly

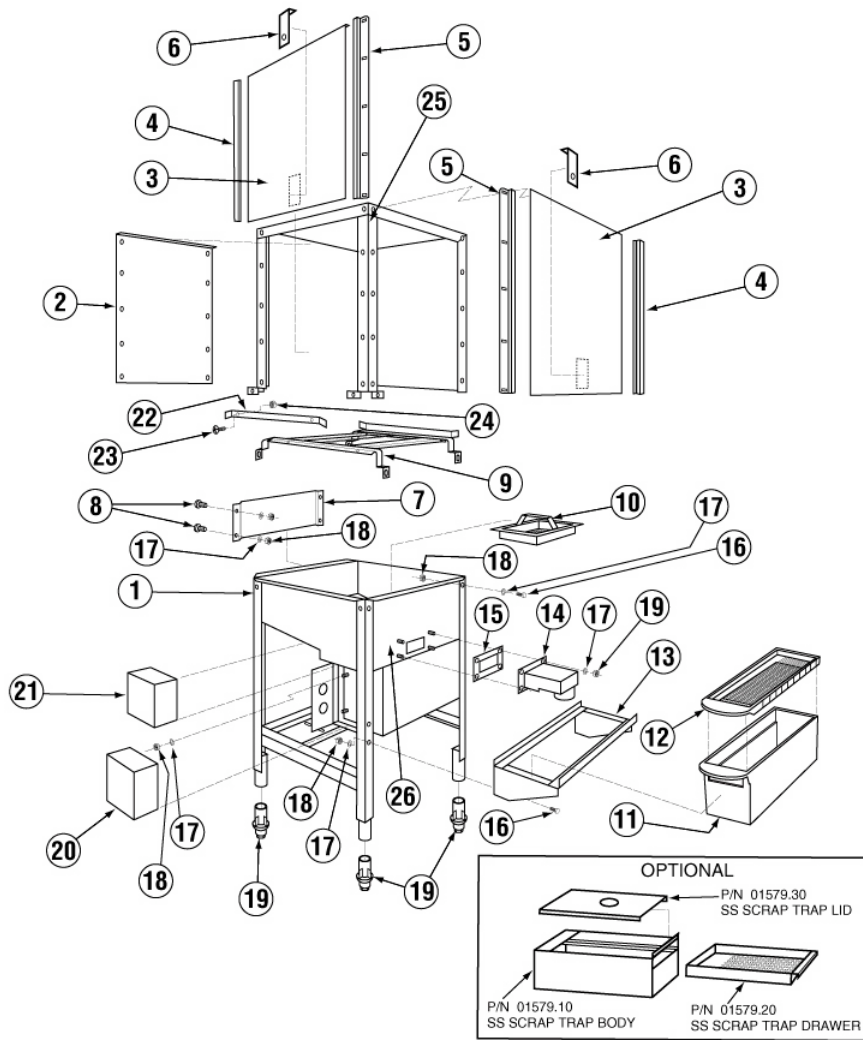

ITEM NO.	NO. REQ'D	P/N	DESCRIPTION
1	1	17532.00	Stand
2	1	17506.50	Door Panel Corner
3	2	17506.00	Door
4	4	00636.17	E Z Door Glide
5	4	17554.00	Door Guide
6	2	17552.00	Door Stop
7	1	17507.10	Air Gap Baffle
8	4	00905.00	¼" – 20 x ½ Truss Head Bolt
9	1	01505.10	Tray Track
10	2	17510.00	Strainer Basket
11	1	01577.10	Scrap Trap Body
12	1	01577.20	Scrap Trap Drawer
13	1	17579.00	Scrap Trap Holder

ITEM NO.	NO. REQ'D	P/N	DESCRIPTION
14	1	17511.00	Overflow
15	1	17402.00	Overflow Gasket
16	24	00906.00	¼"-20 x 1/2" Hex Head Bolt
17	56	00924.00	¼" SS Washer
18	30	00912.00	¼"-20 Nylon Lock Nut
19	4	01310.00	Bullet Feet
20	1	07522.50	Wash Tank Heater Cover
21	1	17522.00	Booster Heater Cover
22	1	01505.16	Tray Track Rail
23	2	00941.00	8/32" x 5/8" Pan Head Screw
24	2	03801.00	10/32" Lock Nut
25	1	17530.00	Wrapper
26	1	17531.00	Pan

1.1.3 Drain System Assembly

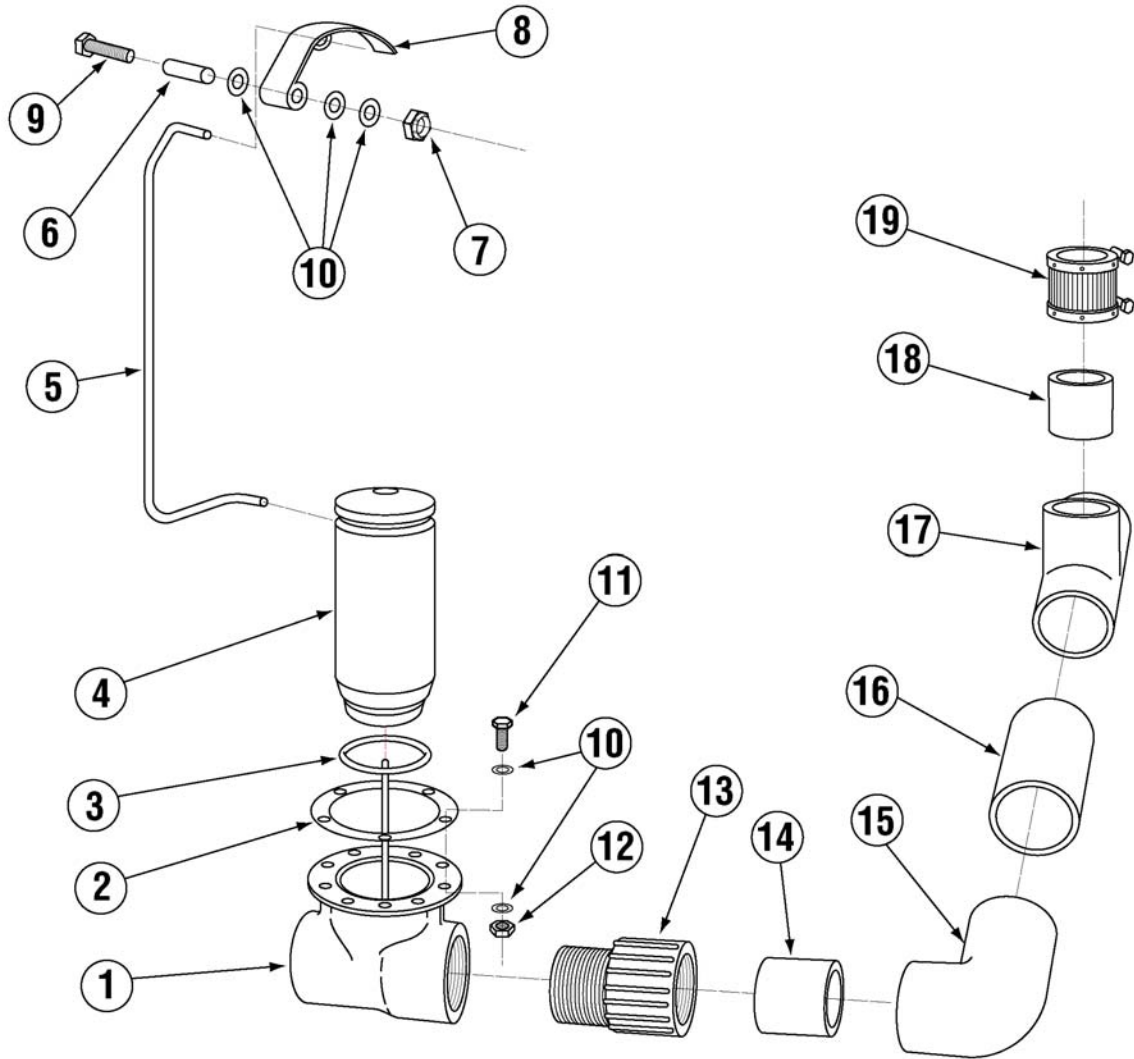

ITEM NO.	NO. REQ'D	P/N	DESCRIPTION
1	1	00113.17	Drain Tee Casting
2	1	00114.00	Drain Tee Gasket
3	1	00121.18	Drain Stopper "O" Ring
*4	1	00121.17	Drain Stopper
5	1	17581.00	Drain Linkage
6	1	17580.50	Drain Linkage Spacer
7	1	00912.00	¼-20 Nylon Lock Nut
8	1	17580.00	Drain Lever
9	1	00910.00	¼"-20 x 1 ½" Hex Head Bolt
* #00121.17 includes #00121.18			

ITEM NO.	NO. REQ'D	P/N	DESCRIPTION
11	6	00901.00	5/16 -18 x 1" Hex Head Bolt
12	6	13805.00	5/16-18 Nylon Lock Nut
13	1	01313.00	2" PVC Slip x MIPT Adapter
14	1	05030.17	2" x 4" PVC Tubing
15	1	01312.00	PVC Slip x Slip 90 Ell
16	1	05030.27	2" x 6" PVC Tubing
17	1	01320.17	2" PVC Tee SxSxS
18	1	05030.10	2" x 3" PVC Tubing
19	1	01315.17	2" No Hub

1.1.4 Plumbing System Assembly

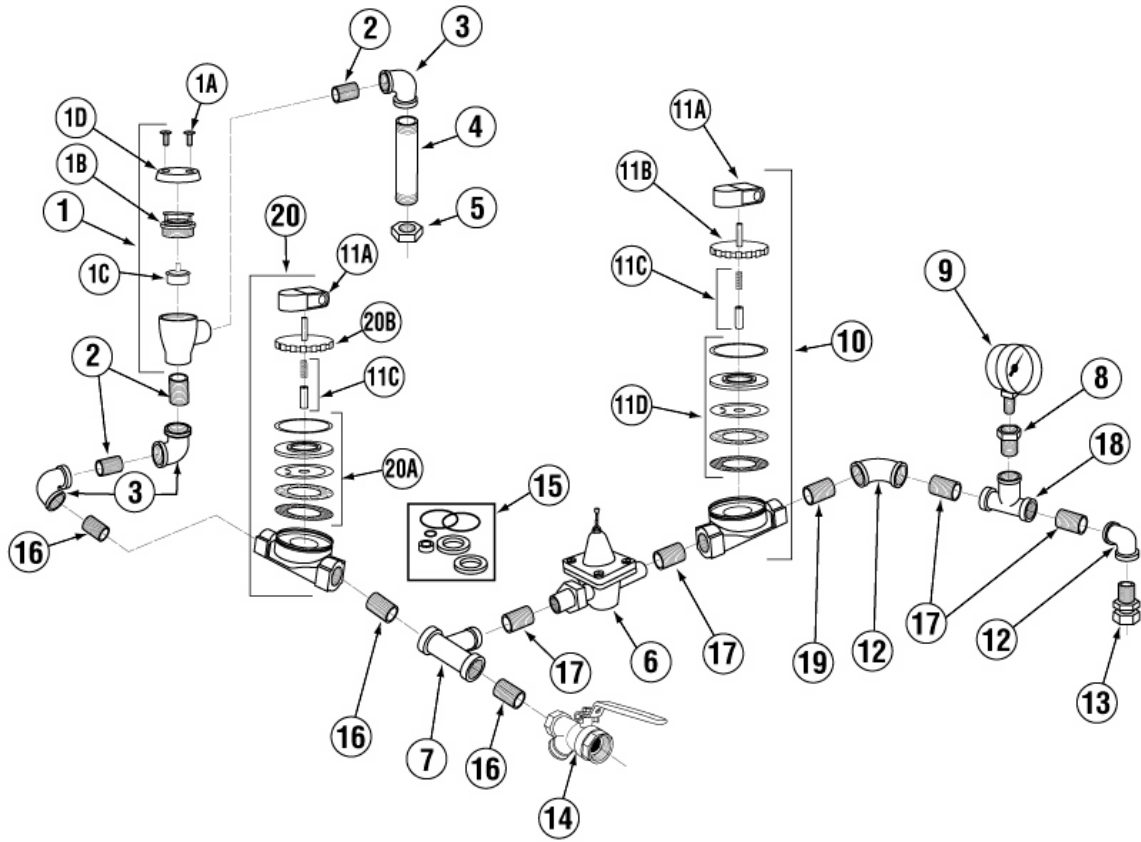

ITEM NO.	NO. REQ'D	P/N	DESCRIPTION
1	1	00710.50	Vacuum Breaker 3/4" Watts
1A	--	00421.51	Pan Head Screw SS 6-32 x 1/4"
1B	--	00735.60	Vacuum Breaker Brass Bonnet 3/4"
1C	--	00735.00	Vacuum Breaker Repair Kit 3/4"
1D	--	00739.50	Vacuum Breaker Cap
2	3	13639.00	Nipple SS 3/4" Close
3	3	13633.00	Elbow FXF Brass 3/4"
4	1	13613.00	Nipple 3/4" x 5 1/2" Brass
5	2	13602.00	Jamb Nut Brass 3/4"
6	1	13602.45	Pressure Regulator 1/2"
7	1	00716.10	Brass Tee 3/4" x 3/4" x 1/2" FXF
8	1	13604.00	Bushing 1/2" x 1/4" Brass
9	1	13605.00	Pressure Gauge
10	1	03603.15	Water Sol Valve 1/2" 220V JE-C Series

ITEM NO.	NO. REQ'D	P/N	DESCRIPTION
11A	1	00738.15	Water Sol Valve Coil 220V
11B	--	03603.20	Water Sol Valve Bonnet 1/2"
11C	--	00786.00	Water Sol Plunger G Style 1/2" & 3/4" with spring
11D	--	00707.00	Water Sol Repair Kit JE 1/2"
12	2	41030.10	Elbow 90° 1/2" FXF
13	1	00760.00	Coupling 5/8" x 1/2" MIP
14	1	13029.00	Strainer Ball Valve 3/4"
15	--	13028.00	3/4" Ball Valve Repair Kit
16	2	13635.10	Nipple Brass 2/4" x 2"
17	4	00742.00	Nipple 1/2" x 1 1/2"
18	1	00743.10	Tee 1/2" FXF
19	1	00780.00	Nipple 1/2" x 2 1/2"
20	-	00705.05	Water Sol Valve 3/4" 220V JE
20A	-	00706.00	Water Sol Repair Kit JE 3/4"
20B	-	00705.20	Water Sol Valve Bonnet 3/4"

1.1.5 Wash Spray System

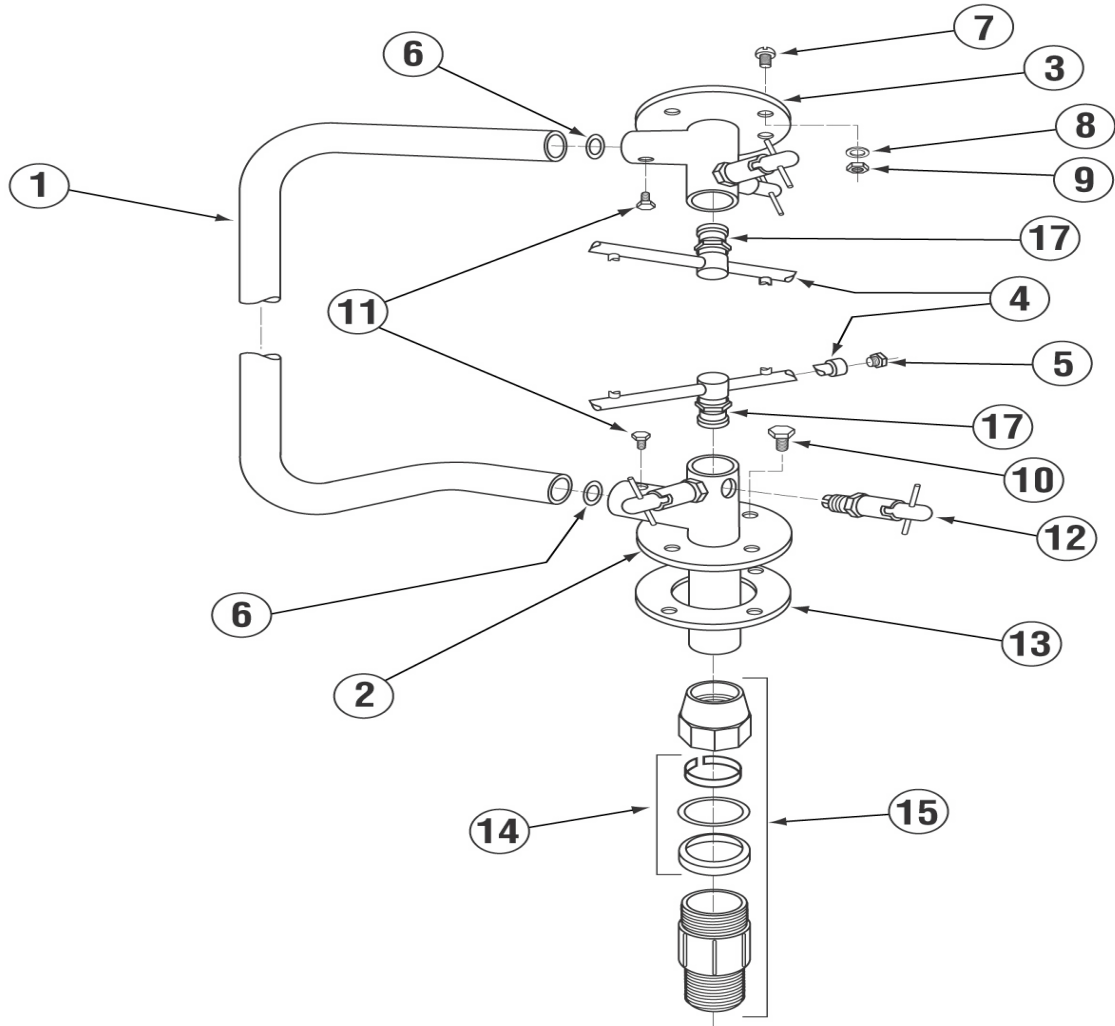

ITEM NO.	NO. REQ'D	P/N	DESCRIPTION
1	1	00303.17	Manifold
*2	1	00360.24	Lower Spray Base Assembly
**3	1	00361.10	Upper Spray Base Assembly
4	2	00304.17	Wash Spray Arm
5	4	00308.50	Spray Arm End Plug SS
6	2	00302.51	Spray Base "O" Ring
7	4	00905.00	Truss Head Bolt 1/4"-20"x1/2"
8	12	00924.00	SS Washer 1/4"

ITEM NO.	NO. REQ'D	P/N	DESCRIPTION
9	8	00912.00	Nylon Lock Nut 1/4" – 20
10	4	00914.10	Hex Head Bolt 1/4"-20"x5/8"
11	2	00966.10	Hex Head SS Bolt 10-32
12	4	00363.00	Spray Base Lock Pin
13	1	00302.00	Spray Base Gasket
14	1	00225.00	Compression Gasket
15	1	00221.20	1" Comp. Fit.x1"MIP SS
16	1	00759.17	Base Quick Release W/Nipple
17	2	00341.00	Spray Arm Bearing

**P/N 00361.10 Includes Items 11,12 & 6

*P/N 00360.24 Includes Items 11, 12 & 6

1.1.6 Final Rinse System

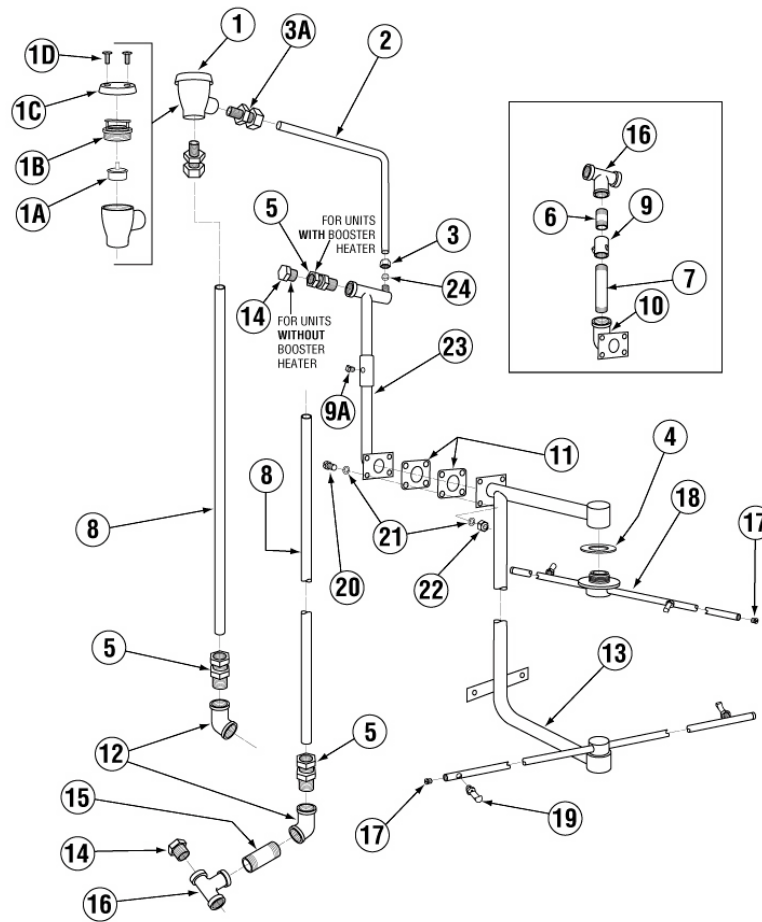

ITEM NO.	NO. REQ'D	P/N	DESCRIPTION
1	1	03624.00	1/2" Vacuum Breaker Watts
1A	--	03623.00	1/2" Vacuum Brkr Kit- Watts
1B	--	03624.25	1/2" Brass Bonnet
1C	--	00739.50	3/4" Vacuum Breaker Cap SS
1D	--	00421.51	6-32 x 1/4" SS Pan Head Screw Phillips
2	1	05004.10	3/8" SS Tubing
3	1	13607.10	3/8" Comp x 1/2" MIP Elbow
3A	1	00436.20	Comp Fitting Nut
4	2	04305.17	Bearing Gasket
5	4	00760.00	5/8" Comp x 1/2" MIP Adapter
6	1	13629.00	1/2" S.S. Close Nipple
7	1	13629.82	Nipple SS 1/2" x 5 1/2"
8	2	05007.17	5/8" OD .049 Wall 304 SS Tubing
9	1	13669.45	Mixing Chamber SS
9A	2	03232.00	1/8" Male Plug

ITEM NO.	NO. REQ'D	P/N	DESCRIPTION
10	1	13306.17	Final Rinse Elbow Assy
11	2	04306.00	Square Manifold Gasket
12	2	41030.10	1/2" 90 deg Ell FxF (Rm)
13	1	17401.00	Final Rinse Manifold
14	2	13642.00	1/2" Brass Plug
15	1	00780.00	Nipple Bras 1/2" x 2 1/2"
16	1	00743.10	1/2" Tee F x F x F
17	4	00308.17	Rinse Arm SS End Plug
18	2	00304.19	Rinse Arm w/Bearing
19	8	13304.55	SS Final Rinse Spray Jet Ht
20	4	00929.00	1/4-20 X 3/4 Bolt
21	8	00926.00	SS Washer 5/16"
22	4	00912.00	1/4"-20 Nylon Lock Nut
23	1	13607.00	Water Inlet
24	1	13607.20	Comp Fitting Sleeve

1.1.7 Door Handle Assembly

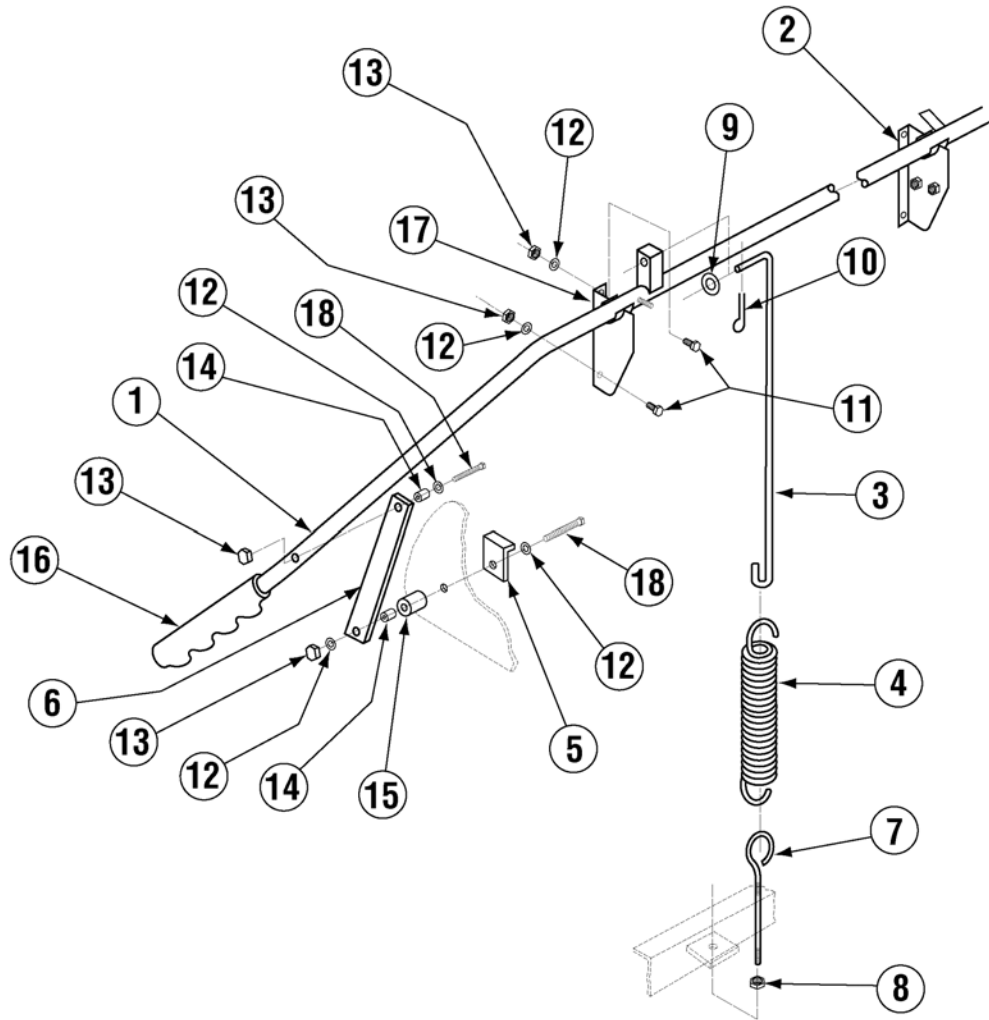

ITEM NO.	NO. REQ'D	P/N	DESCRIPTION
1	1	00613.32	Door Handle
2	1	01556.50	Right Door Handle Support 1"
3	2	00603.07	Door Spring Extension Rod
4	2	00602.00	Door Spring
5	2	17552.00	Door Stop
6	2	01553.00	Door Handle Link
7	2	00606.00	5/16"-18 x 7" Eyebolt
8	2	00913.00	5/16"-18" Nut
9	2	00926.00	5/16" SS Washer

ITEM NO.	NO. REQ'D	P/N	DESCRIPTION
10	2	00900.00	Cotter Pin
11	4	00906.00	¼"-20 x ½" Hex Head screw
12	8	00924.00	¼" SS Washer
13	8	00912.00	¼"-20" Nylon Insert Lock Nut
14	4	00610.00	Door Handle Spacer (Small)
15	4	00611.00	Door Handle Spacer (Large)
16	2	00607.04	Door Handle Grip
17	1	01555.50	Left Door Handle Support
18	4	00903.00	¼"-20 x 1 ¾" Hex Screw

1.1.8 Corner Door Handle Assembly

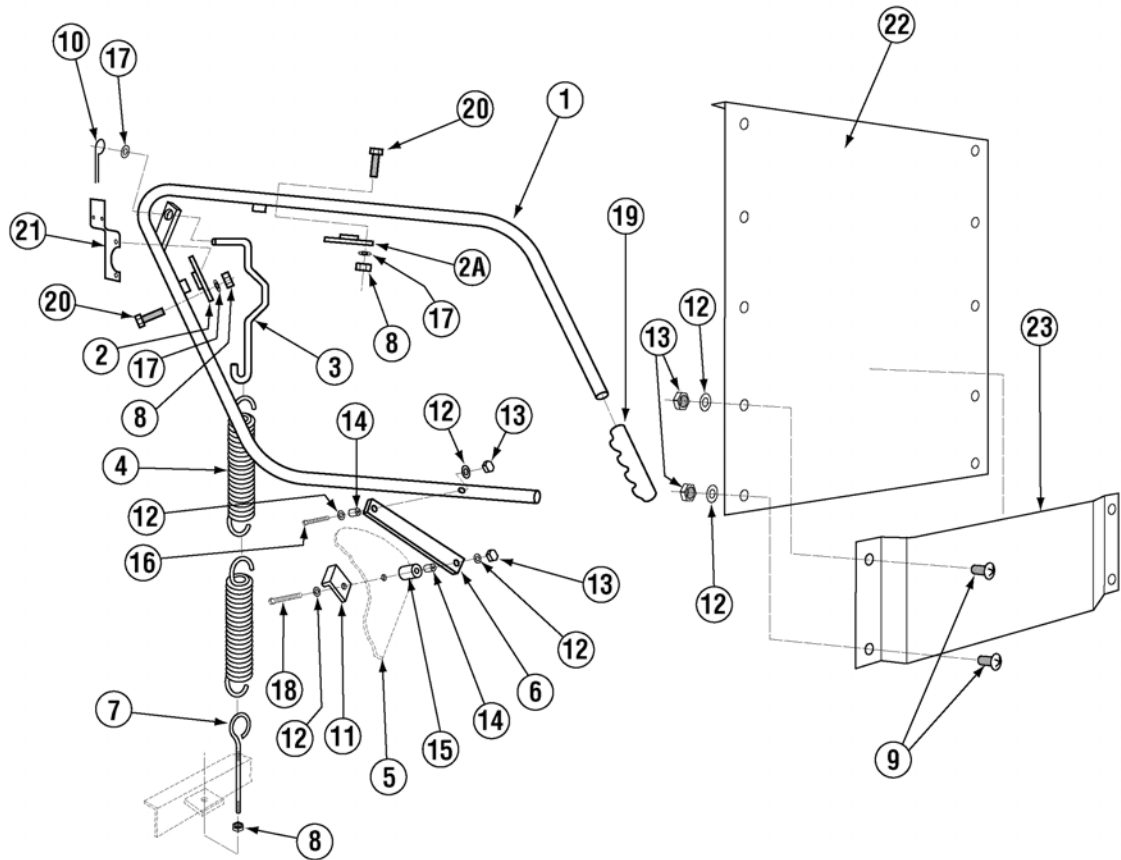

ITEM NO.	NO. REQ'D	P/N	DESCRIPTION
1	1	00613.04	Door Handle
2	1	00619.34	Door Handle Mntg Plate Long
2A	1	00619.44	Door Handle Mntg Plate Short
3	1	00603.04	Door Spring Extension
4	2	00602.00	Door Spring
5	2	17506.00	Door
6	2	01553.00	Door Handle Link
7	1	00606.00	5/16"-18 x 7" Eyebolt
8	9	00913.00	5/16"-18" Nut
9	10	00905.00	1/4"-20 x 1/2" Truss Head Bolt
10	1	00900.00	Cotter Pin
11	2	01552.00	Door Stop
12	16	00924.00	1/4" SS Washer

ITEM NO.	NO. REQ'D	P/N	DESCRIPTION
13	14	00912.00	1/4"-20 Nylon Lock Nut
14	4	00610.00	Door Handle Spacer (Sm)
15	4	00611.00	Door Handle Spacer (Lg)
16	2	00903.00	1/4"-20 x 1 3/4" Hex Head Bolt
17	9	00926.00	5/16" SS Washer
18	2	00910.00	1/4"-20 x 1/2" Hex Head Bolt
19	2	00607.04	Door Handle Cap
20	8	00920.00	5/16-18 x 3/4" Hex Head Bolt
21	1	00563.30	Limit Switch Door Bracket
22	1	17506.50	Door Panel Corner
23	1	17507.10	Air Gap Corner

1.1.9 Pump System Assembly

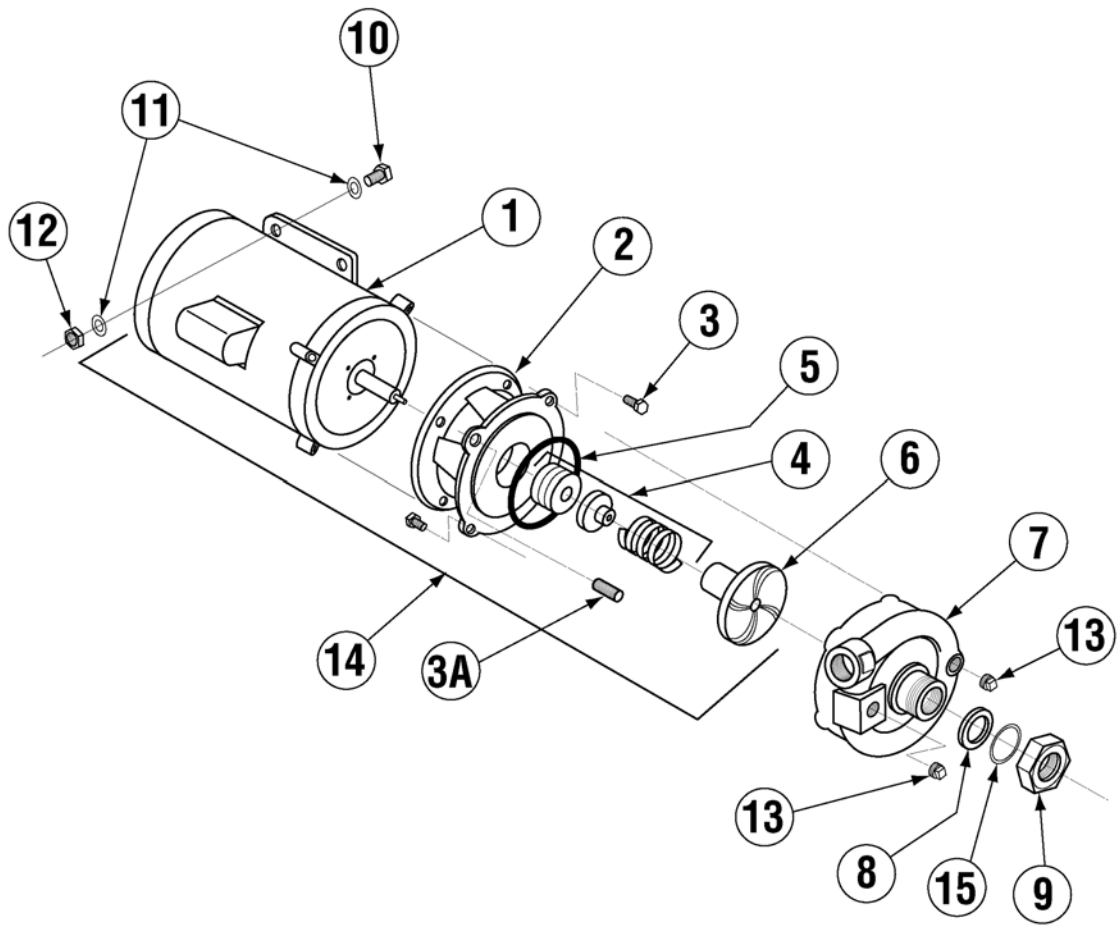

ITEM NO.	NO. REQ'D	P/N	DESCRIPTION
1	1	00201.00	Pump Motor 1 HP
2	1	03224.00	Small Pump Base
3	6	00921.00	3/8"-16 x 34" Hex Head Bolt
3A	2	00975.00	3/8-16 x 1 1/2" Stud
4	1	00206.00	Pump Seal Kit
5	1	03226.00	Pump "O" Ring
6	1	03222.05	Impeller
7	1	04206.00	Pump Cover

ITEM NO.	NO. REQ'D	P/N	DESCRIPTION
8	1	00208.00	Slip Joint Nut Gasket
9	1	04204.00	Compression Nut (2.5)
10	2	00906.00	1/4"-20 x 1/2" Hex Bolt
11	2	00924.00	1/4" SS Washer
12	2	00912.00	1/4"-20 Nylon Lock Nut
13	2	00238.00	3/8" Male Plug
*14	Assy.	00200.10	Pump Assy
15	1	00208.20	Slip Joint Nut Friction Ring

*P/N 00200.10 Includes Items 1,2,3,4,5 and 6

1.1.10 Old Wash Tank Heater (Square Flange)

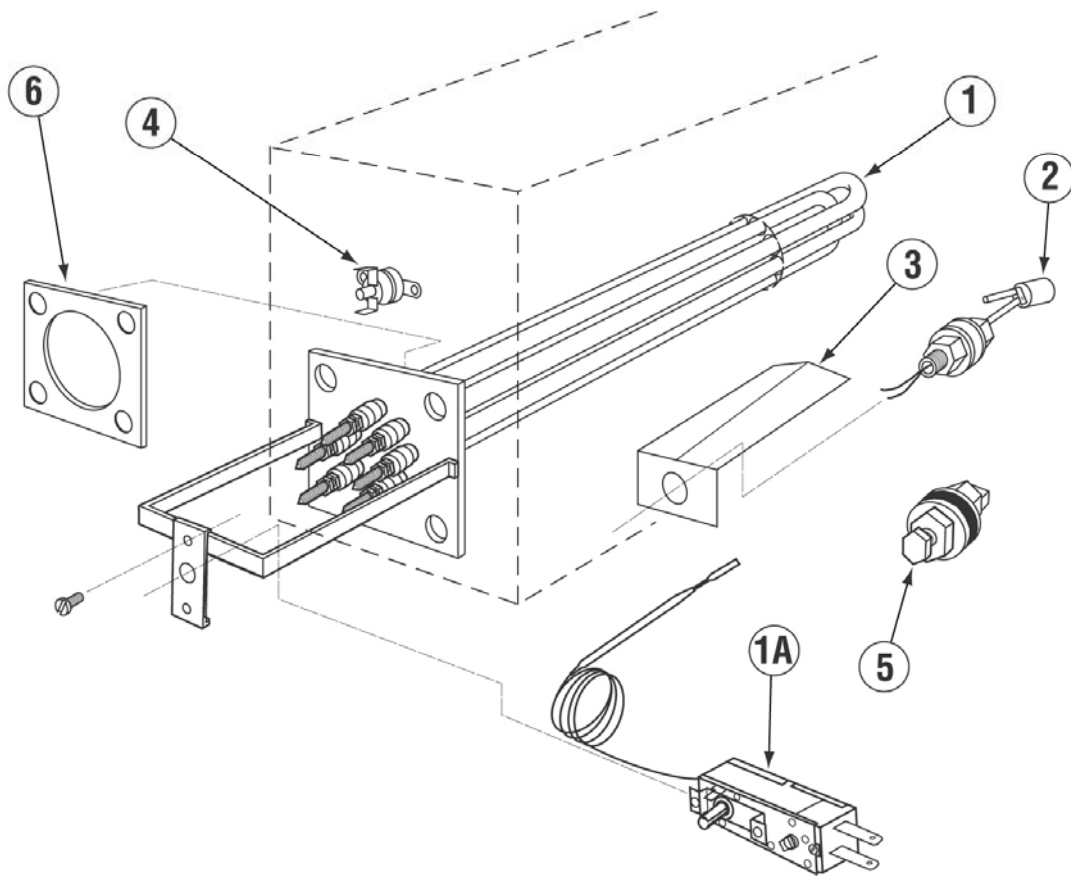

ITEM NO.	NO. REQ'D	P/N	DESCRIPTION
1	1	13417.65	Wash Tank Heater 5KW 3PH
	1	13417.64	Wash Tank Heater 7KW 3PH
1A	1	13417.89	Heater Thermostat
2	1	13463.10	Liquid Level Switch
3	1	13463.50	Liquid Level Switch Shield
4	1	17523.51	Hi-Limit Switch - Wash 250 Degrees
5	1	13477.20	7/8" Probe Hole Plug
6	1	13417.45	Wash Tank Heater Gasket

1.1.11 Old Booster Heater (Square Flange)

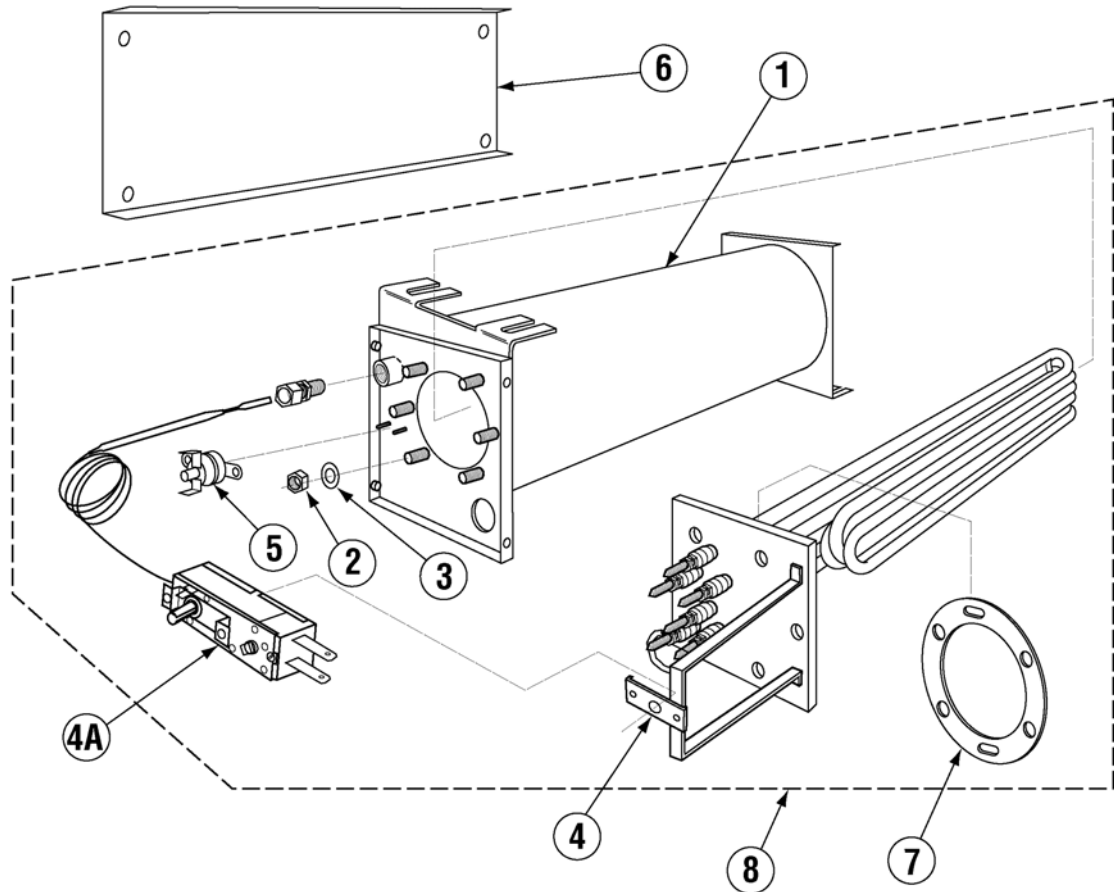

ITEM NO.	NO. REQ'D	P/N	DESCRIPTION
1	1	17550.00	Booster Tank
2	6	13805.00	Nylon Lock Nut 5/6"-18
3	6	00926.00	Washer SS 5/16"
**4	1	13417.67	Immersion Heater 12KW 3PH
4A	1	13417.89	Thermostat 12KW Heater
5	1	17523.51	Hi-Limit Switch-Booster 250 degrees
6	1	17520.00	Booster Heater Shield
7	1	13417.47	Booster Heater Gasket
8	1	17560.00	Complete Assembly
*For Straight Through Applications Only.			
**Includes Gasket #13417.47			

1.1.12 New Wash Tank Heater (Triangular Flange)

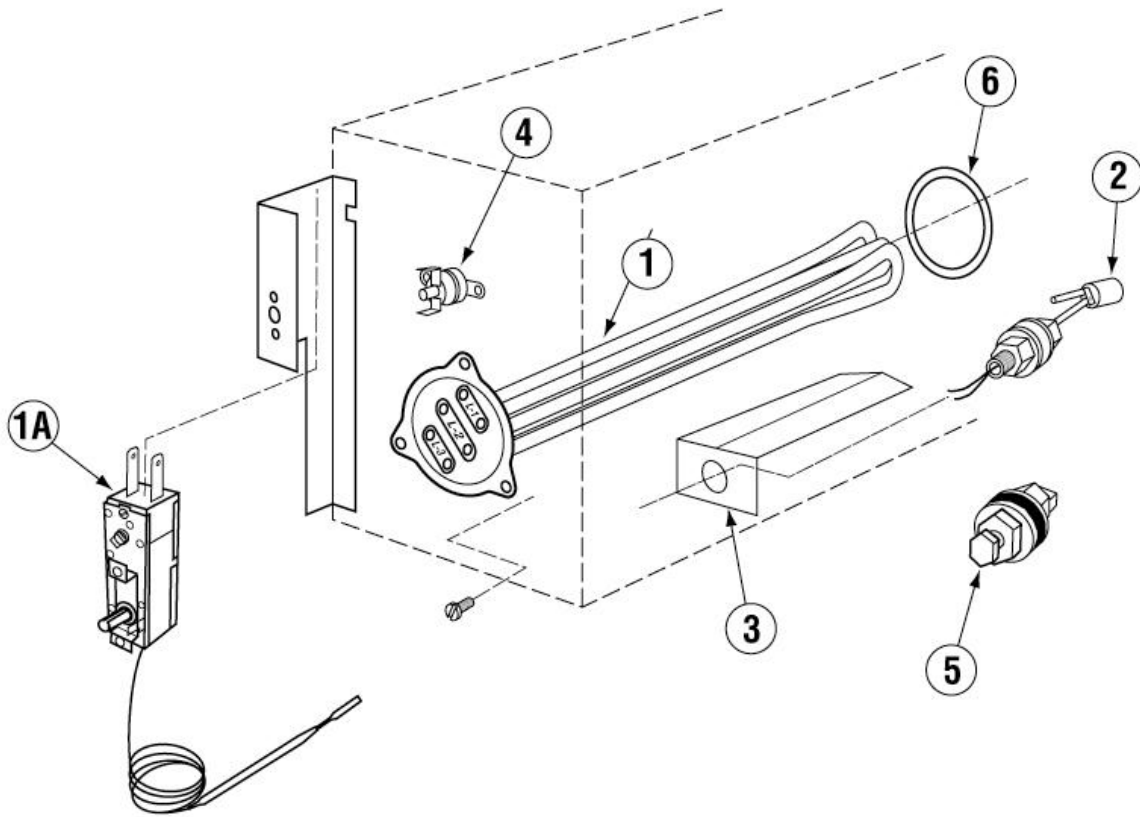

ITEM NO.	NO. REQ'D	P/N	DESCRIPTION
1	1	15518.00	Heater 6kW 220V Triangular Flange
1A	1	13417.92	Heater Thermostat
2	1	13463.14	Liquid Level Switch
3	1	13463.50	Liquid Level Switch Shield
4	1	17523.51	Hi-Limit Switch - Wash 250 Degrees
5	1	13477.20	7/8" Probe Hole Plug
6	1	15518.10	Gasket for Triangular Flange Heater

1.1.13 New Booster Heater (Triangular Flange)

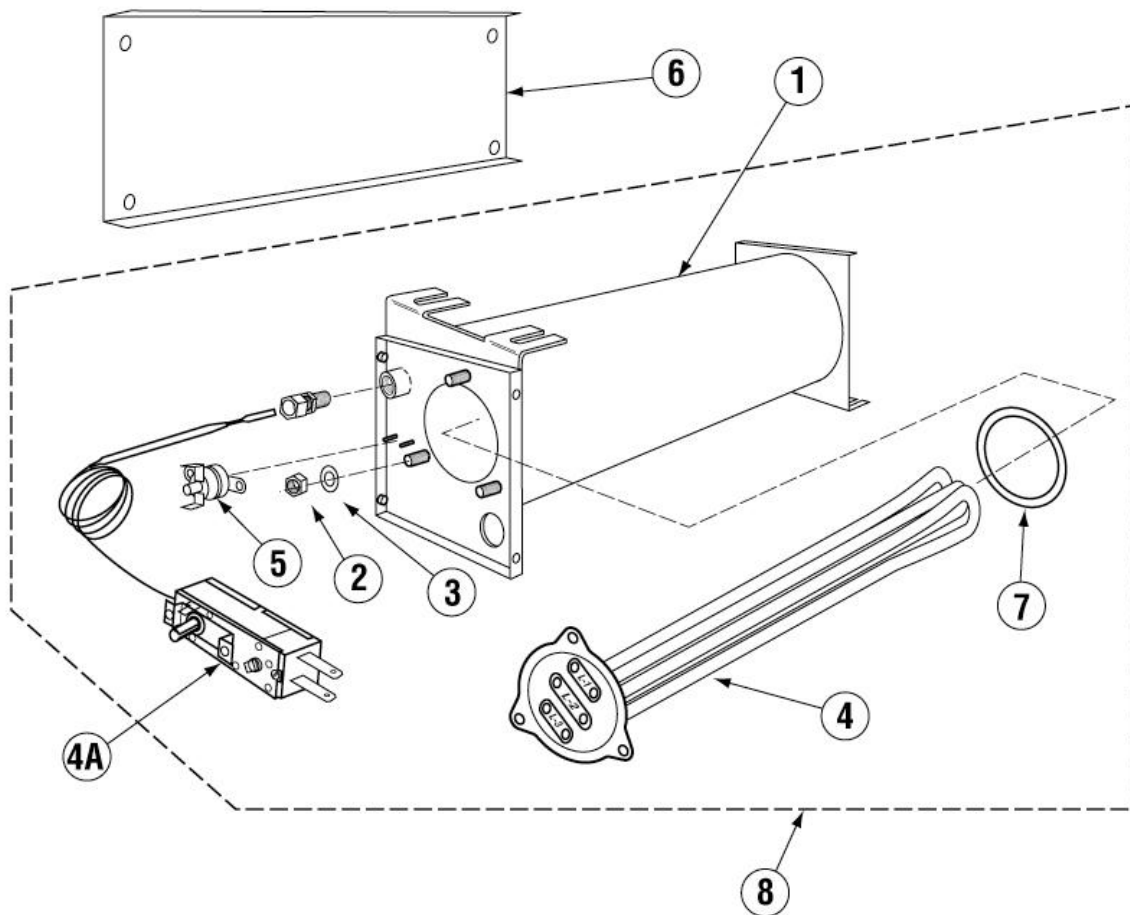

ITEM NO.	NO. REQ'D	P/N	DESCRIPTION
1	1	17550.00	Booster Tank
2	3	13805.00	Nylon Lock Nut 5/6"-18
3	3	00926.00	Washer SS 5/16"
4	1	13422.71	240V 12KW Triangular Immersion Htr
4A	1	13417.92	Thermostat 12KW Heater
5	1	17523.51	Hi-Limit Switch-Booster 250 degrees
6	1	17520.00	Booster Heater Shield
7	1	15518.10	Gasket for Triangular Flange Heater
8	1	17560.00	Complete Assembly

1.1.14 Wiring Harnesses

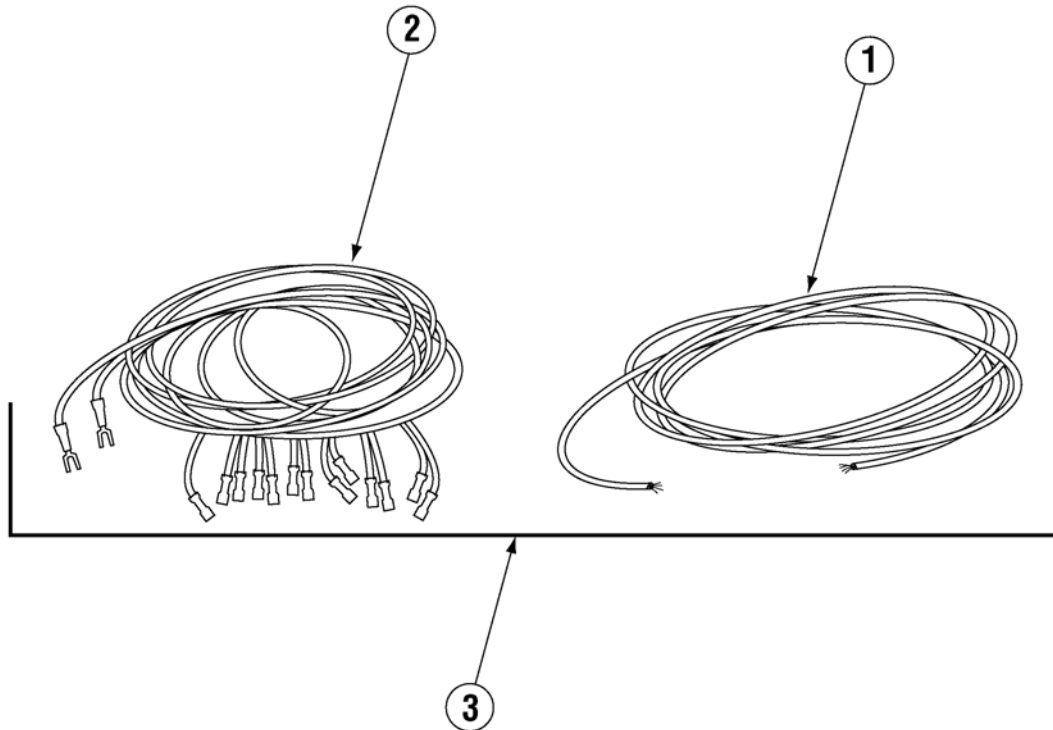

ITEM NO.	NO. REQ'D	P/N	DESCRIPTION
1	1	17514.00	Harness (Without Booster)
2	1	17514.17	Booster Wiring Harness
3	--	00414.17	Harness (Complete)

1.1.15 480V Control Box Assembly p/n 18611.48 (480V machines only)

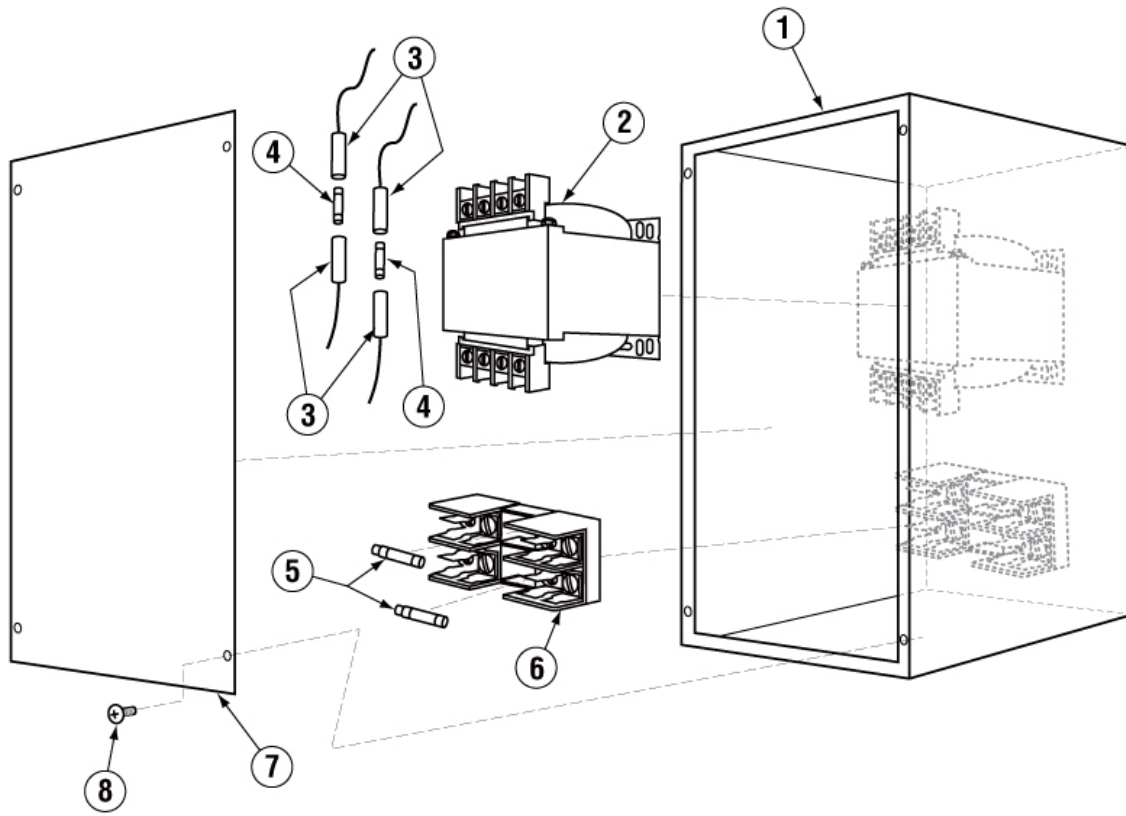

ITEM NO.	NO. REQ'D	P/N	DESCRIPTION
1	1	13905.12	Transformer Box
2	1	13423.82	Transformer 480V - 240V
3	2	13403.21	Fuse Holder - Inline
4	2	13403.40	Fuse 1.25 Amp 230V Slow Blow
5	2	13402.10	Fuse 1.50 Amp 600V Slow Blow
6	1	13420.10	Fuse Clip 2-Poll, Pressure Plate
7	1	13905.22	Transformer Box Lid
8	4	00940.50	10-32 X 3/8 Truss Head Screw

1.1.16 Control Box Assembly

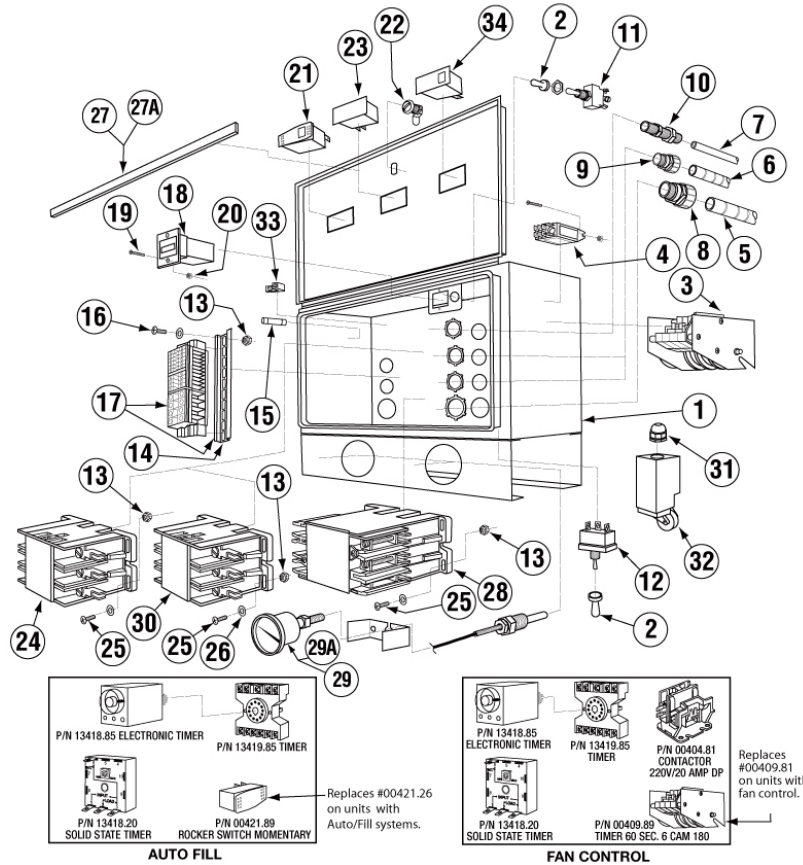

ITEM NO.	NO. REQ'D	P/N	DESCRIPTION
1	1	17503.00	Control Box
2	2	00470.10	Toggle Switch Rubber Boot
3	1	00409.81	Timer CMA-180
4	1(2)*	00631.05	Ice Cube Relay 220V
5	6 Ft.	00400.85	Conduit 3/4" Sealite
6	6 Ft.	00400.10	Conduit 1/2" Sealite
7	2 Ft.	00400.00	Conduit 3/8" Sealite
8	1	00401.85	St-3/4" Straight Connector
9	1	00401.10	St-1/2" Straight Connector
10	1	00401.00	St-3/8" Straight Connector
11	1	00475.00	Delimer Switch DPDT 15A
12	1	03470.00	Toggle Switch Momentary (Screw Terminal)
13	8	03801.00	Nylon Lock Nut 10-32
14	1	17400.06	Mountain Din Rail
15	1	13403.26	Fuse 3A/250V Slow Blow
16	2	00941.00	Pan Head Screw 10 -32 x 5/8"
17	1	17400.17	Terminal Block Assembly
17A	2	17400.04	30 Amp Terminal Block-Red
17B	3	17400.03	60 Amp Terminal Block-Black
17C	4	17400.02	85 Amp Terminal Block-Natural
17D	2	17400.08	30 Amp Terminal Block-Blue

* Second relay for the machine with booster heater

ITEM NO.	NO. REQ'D	P/N	DESCRIPTION
17E	2	17400.09	30 Amp Terminal Block-Natural
17F	1	17400.07	60 Amp Terminal Block-Green
18	1	03408.55	Counter Face Mount 220V
19	4	00911.00	Pan Head Screw 8-32 x 1/2"
20	4	00927.00	Lock Nut 8-32
21	1	00421.90	Power Switch
22	1	00449.50	Keyless Lock
23	1	00421.26	Rocker Switch Hole Plug
24	1	00404.85	Motor Contactor 208/240V 20A
25	6	13825.00	Pan Head Screw 8-31 x 1"
26	6	04806.00	#10 Brass Washer
27	2	17503.17	Control Box Sponge Long
27A	2	17503.18	Control Box Sponge Short
28	1**	13003.17	Contactor 60A 3 Pole 220V
29	1	03202.00	Thermometer "Wash"
29A	1	03202.00	Thermometer "Rinse"
29B	--	03202.00	Thermometer Bracket
30	1	13003.50	Heater Contactor 40 Amp
31	1	00562.60	Door Roller Switch Connector
32	1	00562.00	Door Roller Switch
33	1	13426.50	Ground Block
34	1	00421.78	Illuminated Plug

** Only for the machines with booster heater

1.2. Unique Parts For CMA-180TS

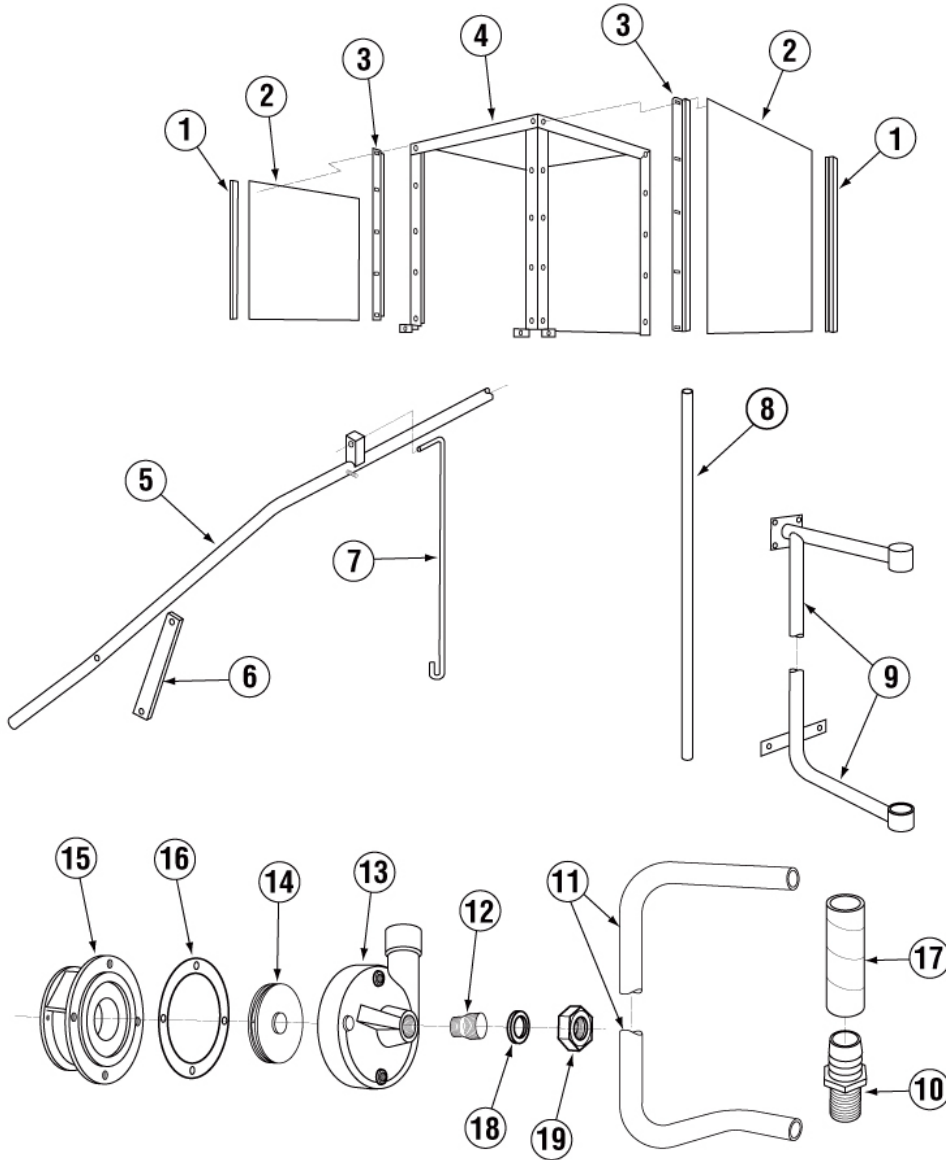

ITEM NO.	NO. REQ'D	P/N	DESCRIPTION
1	6	00636.27	Door Guide Material
2	3	17506.20	Scullery Door
3	6	17554.20	Scullery Door Guide
4	1	17530.20	Scullery Wrapper
5	1	00613.27	Door Handle S
6	2	01553.20	Door Handle Link S
7	2	00603.53	Door Spring Extension Rod
8	2	05007.27	Booster Water Line
9	1	17401.20	Final Rinse Manifold

ITEM NO.	NO. REQ'D	P/N	DESCRIPTION
10	1	50302.06	1" MPT x 1" Barb PVC
11	1	00303.27	Manifold
12	1	00212.50	1-1/2"x1-1/4" Adapter
13	1	00204.00	Pump Cover Large
14	1	00203.05	Impeller 4-1/2"
15	1	00202.00	Pump Base
16	1	00205.00	Pump Gasket
17	1	03108.60	Transfer Hose 1" Reinf.
18	1	00208.40	Slip Joint Nut O Ring
19	1	00207.00	Slip Joint Nut 1 1/2 x 1/4

1.3. Unique Parts For CMA-180TC

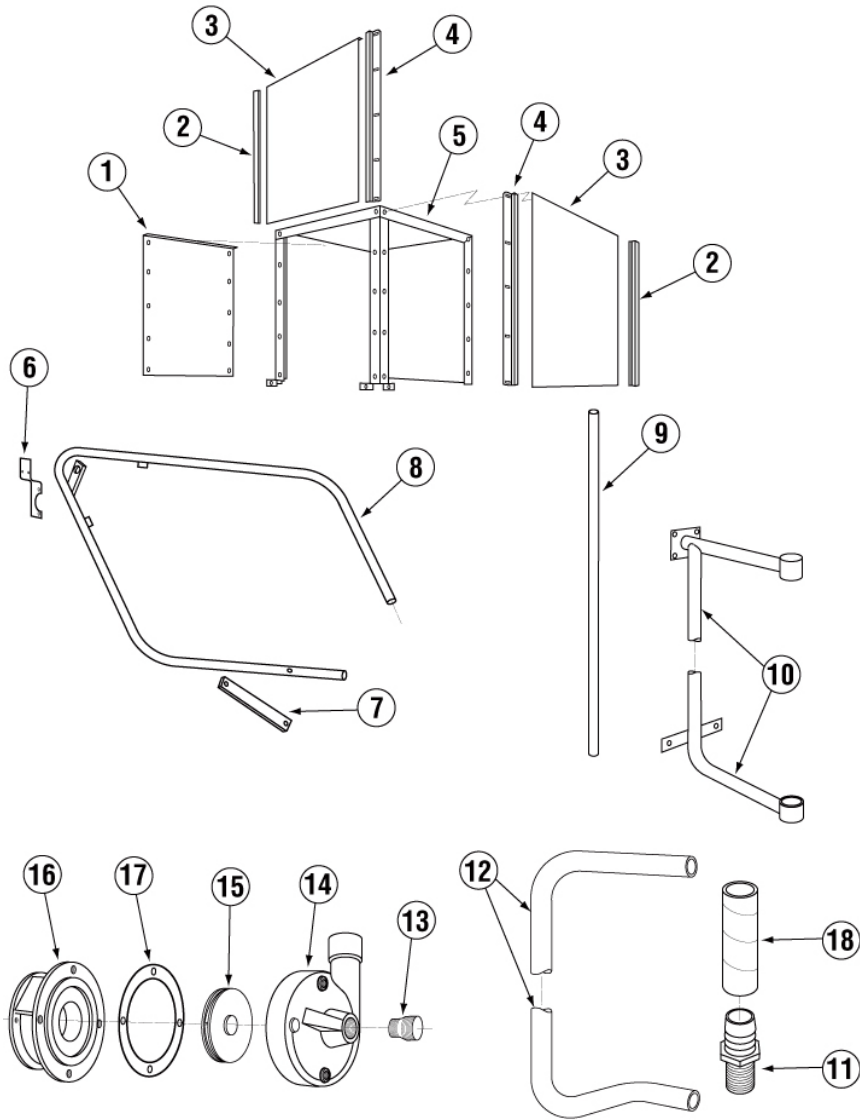

ITEM NO.	NO. REQ'D	P/N	DESCRIPTION
1	1	17506.20	Door Panel Scullery Corner
2	6	00636.27	Door Guide Material
3	2	17506.20	Scullery Door
4	4	17554.20	Scullery Door Guide
5	1	17530.20	Scullery Wrapper
6	1	00563.60	Limit Switch Door Bracket
7	2	01553.20	Door Handle Link S
8	1	00613.34	Door Handle S Corner
9	2	05007.27	Booster Water Line

ITEM NO.	NO. REQ'D	P/N	DESCRIPTION
10	1	17401.20	Final Rinse Manifold
11	1	50302.06	1" MPT x 1" Barb PVC
12	1	00303.27	Manifold
13	1	00212.50	1-1/2"x1-1/4"Adapter
14	1	00204.00	Pump Cover Large
15	1	00203.05	Impeller 4-1/2"
16	1	00202.00	Pump Base
17	1	00205.00	Pump Gasket
18	1	03108.60	Transfer Hose 1" Reinf.

2. Power Switch Bulb Replacement Instructions

NOTE: For Old Style Machines ONLY -- Manufactured prior to May 2002

TO REPLACE BULB

1. Using a 5mm-screw driver dismount the light module from the actuator as shown in illustration 1 & 2.
2. Replace the burnt bulb with a new one P/N 17421.10 by twisting the bulb 90 degrees.
3. Mount the light module by snapping it onto the actuator as shown in illustration 3.

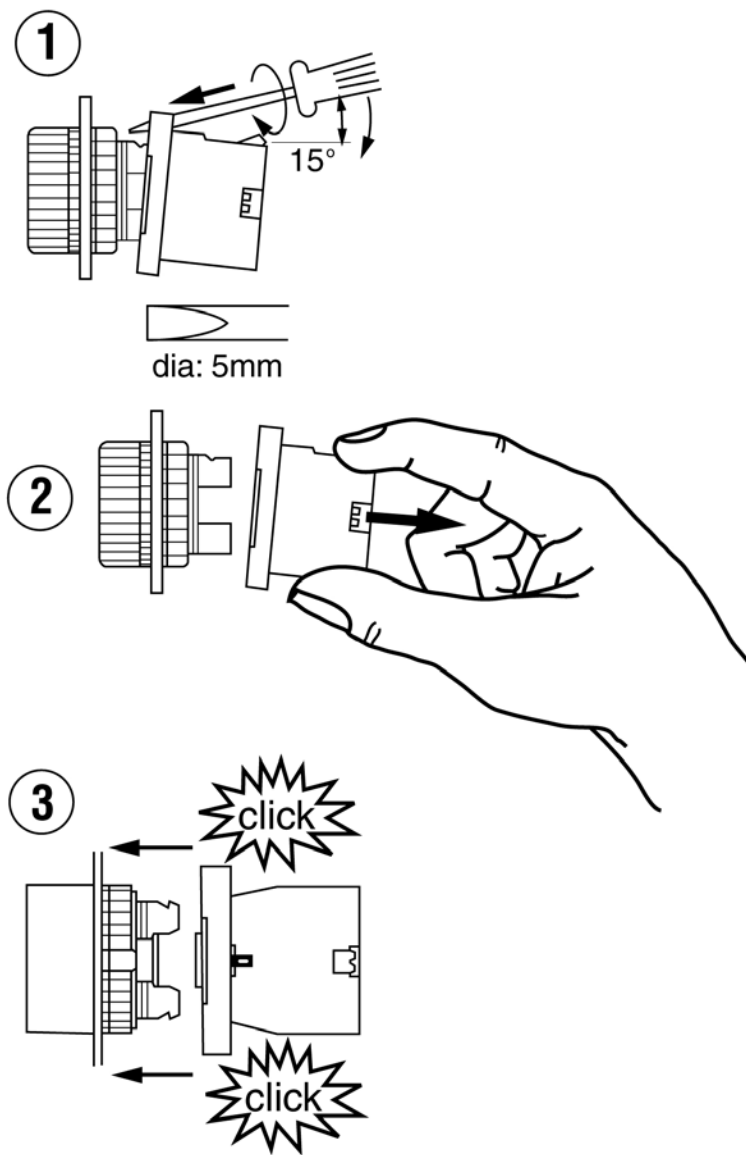

3. 180 Conversion Kit – Corner to Straight #00617.18

INSTRUCTIONS:

1. Open dishmachine doors to their highest position so that there is little spring resistance on the door handle. Remove hardware holding the door handle to the door linkage. Save all the washers and spacers. With the door handle in "UP" position, lift spring and remove from extension rod. Remove the nut attaching the eyebolt and save all hardware.
2. To remove the door handle, simply unscrew the four bolts holding the door handle mounting plates and slide the complete assembly up and off of the cabinet. Use the bolts, nuts and washers to plug the holes in the back of the cabinet.
3. Remove door panel & hardware from left side of machine, and install door guides from kit. Remove front door and relocate to left side of machine. The service door will be used to seal off this side of machine. Relocate tray track guide to front service door side of tray track.
4. Using provided nuts, bolts and washers; mount the left and right door handle supports on the back of the cabinet. Insert the eyebolts into the brackets on the back of the dishmachine stand and screw the nuts on just enough to hold them in place. Hook both door springs and door spring extension rods on to the door handle and secure them with the washers and cotter pins. Then simply rest the door handle on the door handle supports. (You may have to lift the door handle to reach the handle supports.)
5. Swing the door handle downwards to reach the door linkages; and using the two provided bolts and existing washers and spacers, attach the door linkages to the door handle. Adjust the tension in the spring by tightening the nuts under the eyebolt bracket so that the doors can slide up and down freely. Mount the provided door handle grips on the ends of the door handle.
6. Eyebolt adjustment nuts should be adjusted to the point the doors begin to lift from a closed position. Both eyebolts should be adjusted the same. SEE "Illustration #1" for the proper location of all door handle hardware for CMA 180-S.
7. "Illustration #2" shows CMA 180-S and CMA 180-C door handle assembly.

ILLUSTRATION #1

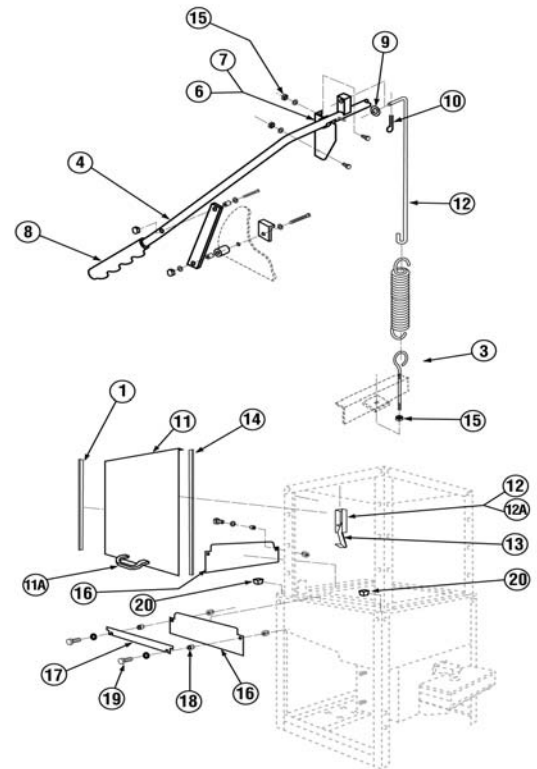
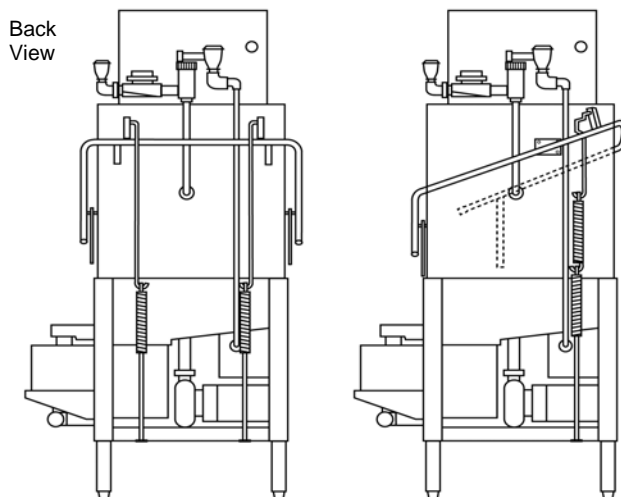

ILLUSTRATION #2



ITEM NO.	NO. REQ'D	P/N	DESCRIPTION
1	2	00636.17	EZ Glide Door Guide
2	2	00603.07	Door Spring Extension Rod
3	1	00606.00	5/16"-18 x 7" Eyebolt
4	1	00613.17	Door Handle
5	2	00913.00	5/16"-18 SS Nut
6	1	01555.50	L.H. Door Handle Support
7	1	01556.50	R.H. Door Handle Support
8	2	00607.04	Door Handle Grip
9	4	00924.00	¼" SS Washer
10	2	00900.00	Cotter Pin
11	1	17506.00	Service Door
11A	1	00535.30	Door Handle
12	1	13915.00	Door Latch Bracket
12A	1	13915.06	Latch Bracket with Nut
13	1	13701.00	Open Door Latch
14	2	17554.00	Door Glide
15	4	00912.00	¼" 20 Nylon Lock Nut
16	2	17506.60	Door Splashguard-Straight
17	1	17506.65	Service Door Splashguard-S
18	4	00610.00	Spacer Small
19	4	00962.00	¼"-20 x 1 SS Hex Head Bolt
20	2	1222.50	Tank Plug

4. 180 Conversion Kit – Straight to Corner #00617.17

INSTRUCTIONS:

1. Open dishwasher door to its highest position so that there is little spring resistance on the door handle. Remove hardware that holds the door handle to the door linkage. Save all the washers and spacers. Swing the door handle towards the back of the dishwasher and dismount it from the door handle support brackets. Remove the two nuts attaching the eyebolts and save the door springs.
2. Remove the two (2) door-handle support brackets on the back of the cabinet and plug the four holes with original hardware. Remove front door and replace with left door. Remove door guides on left side of machine and attaché item No. 9 door panel-cover. The left door will now be at the front of the machine. Remove and relocate service door splashguard to left side of machine. Remove door latch for service door. The door latch is not needed on the CMA 180-C.
3. With left door facing the front, door panel on the left, and service door splashguard in place, we are now ready to install the door handle.
4. Using provided door handle, door handle mounting plates, 5/16" bolts, nuts and washers; install the door handle as shown in "Illustration #1". Match the mounting plate holes to the cabinet holes and insert all bolts to ensure that the door handle and mounting plates are aligned. Then secure the mounting plate with nuts and washers.

Note: You may install one of the mounting plates first, then insert the door handle pivot post in and mount the other mounting plate last.

5. Attach the provided extension rod to the back of the door handle. Attach one eyebolt to the frame with existing hardware, along with two springs together. Pivot the door handle, positioning handle straight up. You may now connect loop of 2nd spring to the door extension rod. Pull handles forward and down and attach to the door links.
6. Adjust the nut on the eyebolt until the doors begin to lift then back off two turns. See "Illustration #2" for proper location of all door handle hardware included on CMA 180C.
7. "Illustration #3" shows CMA 180-S and CMA 180-C "Door Handle Assembly".

ILLUSTRATION #2

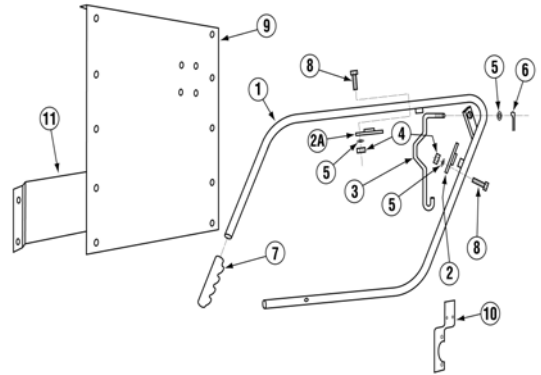

ITEM NO.	NO. REQ'D	P/N	DESCRIPTION
1	1	00613.04	Door Handle
2	1	00619.34	Door Hdl. Mtng. Plate-Long
2A	1	00619.44	Door Hdl. Mtng. Plate-Short
3	1	00603.04	Door Spring Extension
4	9	00913.00	5/16" – 18" Nut
5	9	00926.00	5/16" SS washer
6	1	00900.00	Cotter Pin
7	2	00607.04	Door Handle Grip
8	8	00920.00	5/16"-18 x 3/4" Hex Head Bolt
9	1	17506.50	Door Panel-Cover
10	1	00563.20	Roller Switch Bracket
11	1	17507.10	Air Gap Baffle CMA 180C

ILLUSTRATION #1 Back View

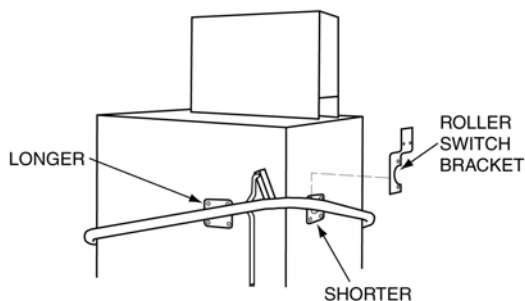

Note: Door handle mounting plates come in two sizes. Longer is mounted on back-right side.

ILLUSTRATION #3 Back View

