



**181GW**  
High Temperature  
Undercounter Glasswasher

**NEW!**  
40" HEIGHT  
FOR UNDER BAR  
GLASSWASHER  
APPLICATION!



MODEL CMA 181GW

**FEATURES:**

- Energy Star Approved.
- 16 gauge 304 Stainless Steel wash tank.
- 30 racks per hour or 600 glasses per hour (20 per 20X20 rack).
- .86 gallons of water per cycle or rack.
- Safety-T-Temp booster heater capable of a 70°F rise. (3 minute cycle)
- 180°F final rinse
- Detergent and rinse chemical pumps.
- Fresh water rinse through upper and lower rotating arms.
- Rotating upper and lower wash arms for maximum glass surface coverage.
- Removable Stainless Steel pump protection screen for easy cleaning..
- Raised wash chamber reduces "bending over" to remove racks
- Gravity drain system.
- **Great application for WINERY companies.**



Top mounted controls are easy to read and simple to operate.



6" legs for increasing the overall height to 40" is standard.



Large 11-1/4" height clearance accommodates larger glassware.

**Options Available: CMA 181GW**

- Stainless Steel Pedestal
- 4 Inch legs Part # 1146.50 (4 needed)



CMA Dishmachines 12700 Knott Street, Garden Grove, CA 92841 • 800-854-6417 • 714-898-8781 • Fax: 714-895-2141 • [www.cmadishmachines.com](http://www.cmadishmachines.com)

CMA reserves the right to modify specifications or discontinue models without prior notification.



**181GW**  
High Temperature  
Undercounter Glasswasher

**WARNING:** Plumbing connections must be made by a qualified service company who will comply with all available Federal, State, and Local Health, Plumbing and Safety codes.

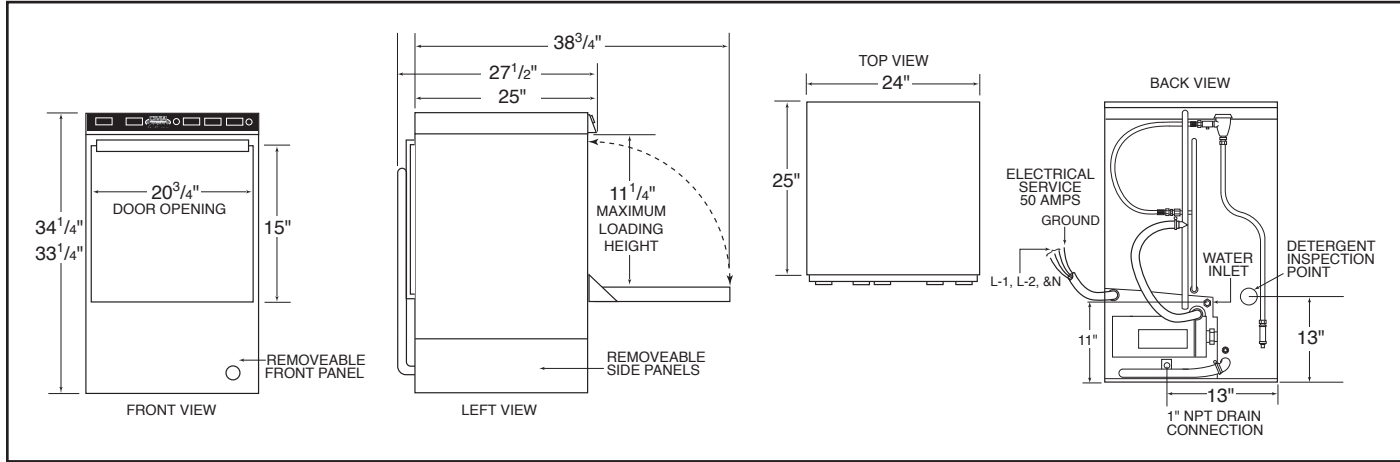

**Specifications:**

CMA-181GW	USA	(Metric)	CMA-180UC	USA	(Metric)
<b>WATER CONSUMPTION</b>			<b>FRAME DIMENSIONS</b>		
PER RACK	.86 GAL.	(3.25 L)	DEPTH	25"	(63.5 CM)
PER HOUR	20.6 GAL.	(77.8 L)	WIDTH	24"	(60.96 CM)
<b>OPERATING CYCLE</b>			HEIGHT	33-1/4"	(84.45 CM)
WASH TIME-SEC	94	94	MAX CLEARANCE FOR DISHES	11-1/4"	(28.6 CM)
RINSE TIME-SEC	16	16	<b>WASH PUMP MOTOR</b>	1 HP	1 HP
DWELL TIME-SEC	10	10	<b>ELECTRICAL RATING*</b>	<b>208 VOLTS</b>	<b>230 VOLTS</b>
TOTAL CYCLE TIME	2 MIN.	2 MIN.	TOTAL AMPS	33.0 AMPS	35.0 AMPS
<b>OPERATING CAPACITY</b>			BOOSTER HEATER KW	5.3 KW	6.5 KW
RACKS PER HOUR	30	30	WASH PUMP MOTOR	3/4 HP	3/4 HP
WASH TANK CAPACITY	2.5 GAL.	(9.46 L)	<b>*MUST CONNECT TO 50 AMP SUPPLY CIRCUIT.</b>		
PUMP CAPACITY	38 GPM	(144 LPM)	THIS SYSTEM REQUIRES THREE POWER WIRES WHICH INCLUDES A CURRENT CARRYING NEUTRAL. AN ADDITIONAL FOURTH WIRE MUST BE PROVIDED FOR MACHINE GROUND.		
<b>WATER REQUIREMENTS</b>			<b>SHIPPING WEIGHT</b>		
REQUIRED MINIMUM TEMP.*	110°F	(43°C)	APPROXIMATE	234#	(106 KG)
RECOMMENDED TEMP.**	140°F	(60°C)	*For machine having "Safe-T-Temp"		
WATER INLET	1/2"	(1.27 CM)	**For faster heat recovery		
DRAIN CONNECTION	1"	(2.54 CM)			
RINSE PRESSURE SET	20 ± 5PSI	1.41 KG/CM²			
<b>CYCLE TEMPERATURES</b>					
WASH-°F	150° F-160° F	(65.5°C/71°C)			
RINSE-°F	180° F-195° F	(82°C/90°C)			

**Summary Specifications: CMA 181GW**

The CMA 181GW undercounter dishwasher provides hot water (180°F) sanitizing through the use of a built-in booster heater. 180°F final rinse safety system ensures proper temperatures in the final rinse by holding wash cycle in run mode until 180°F rinse temperature is detected. The unit comes standard with upper and lower stainless steel wash and final rinse arms, digital LED temperature gauges and easy to operate controls. The CMA 181GW is constructed entirely of stainless steel. Uses standard 20"X20" glass-racks with a 12" door clearance.

**Options Available: CMA 181GW**

- 48" Undercounter Dishtable
- Stainless Steel Pedestal
- 4 Inch legs Part # 1146.50 (4 needed)

