



WIRE DIAGRAM FOR MODEL: CMA-44

w/TRANSFORMER:480/575/600

Rev. 2.09

05/23/03

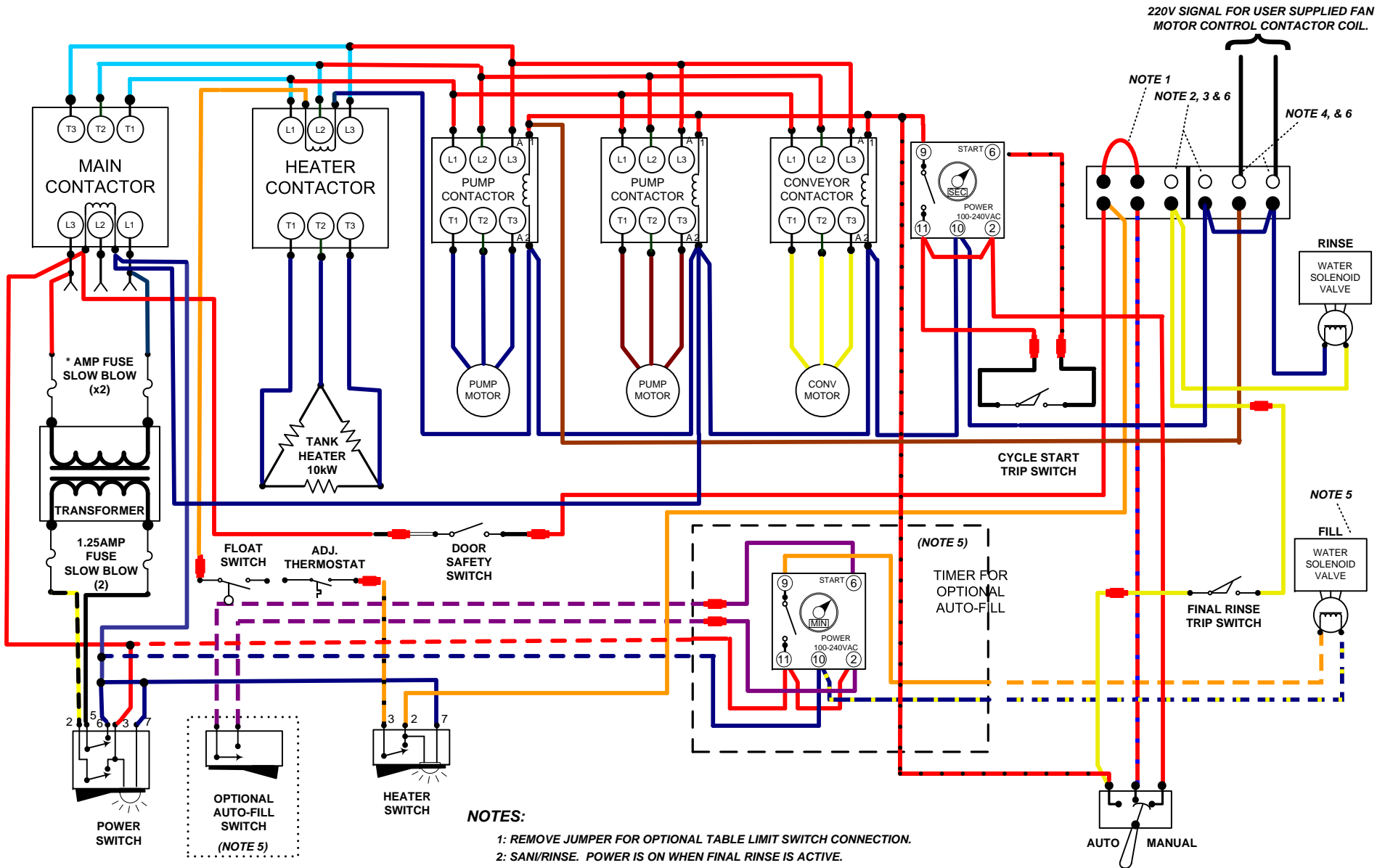

NOTES:

- 1: REMOVE JUMPER FOR OPTIONAL TABLE LIMIT SWITCH CONNECTION.
- 2: SANI/RINSE. POWER IS ON WHEN FINAL RINSE IS ACTIVE.
- 3: CONNECT ONLY TO PRIMARY OF LISTED CLASS 2 TRANSFORMER 208-230V 60Hz MAXIMUM 100VA.
- 4: DETERGENT FEEDER CONNECTIONS AND SIGNAL FOR FAN MOTOR CONTROL CONTACTOR COIL.
- 5: PRESENT ONLY WITH "AUTO-FILL" OPTION.
- 6: COMBINED LOAD OF USER DEVICES (CHEMICAL PUMPS, FAN CONTROLS, ETC.) MUST NOT EXCEED 1.5 AMPS.

* 250 VA Transformer:
 440 Volt application - 1.8 Amp
 480 Volt application - 1.5 Amp
 * 350 VA Transformer - 1.8 Amp