



MODEL CMA-180

Installation & Operation

Rev 2.03



CMA DISHMACHINES
12700 KNOTT AVENUE
GARDEN GROVE, CALIFORNIA 92841
800-854-6417
FAX 714-895-2141

www.cmadishmachines.com

Table of Contents

CMA-180

- 1. SPECIFICATIONS..... 2**
 - 1.1 CMA-180/CMA-180T..... 2
 - 1.1. CMA-180/CMA-180T..... 3
- 2. GETTING STARTED..... 4**
 - 2.1. Introduction to CMA-180..... 4
 - 2.2. Receiving and Installation 5
 - 2.2.1. *Electrical* 5
 - 2.2.2. *Plumbing*..... 5
 - 2.2.3. *Nova Detergent and Rinse Dispenser*..... 5
 - 2.2.4. *Exhaust Fan Control* 8
 - 2.2.5. *Water Tempering Kit* 9
 - 2.2.6. *Installation Checklist*..... 10
 - 2.2.7. *Machine Start-Up Procedures*..... 11
 - 2.2.8. *Electrical Requirements*..... 12
- 3. WIRING OPTIONS 13**
- 4. QUICK SERVICE GUIDE 14**
- 5. INITIAL PARTS KIT P/N 1100.17 15**
- 6. AUTO-FILL SOLID STATE TIMER 16**
- 7. WIRE DIAGRAM 17**
- 8. WIRE DIAGRAM FOR CMA-180 BOOSTER ONLY 18**

1. Specifications

1.1 CMA-180/CMA-180T		Metric Equivalent
WATER CONSUMPTION		
PER RACK	.96 GAL.	(3.6 L)
PER HOUR	52 GAL.	(197 L)
OPERATING CYCLE		
WASH TIME-SEC	49	49
RINSE TIME-SEC	12	12
TOTAL CYCLE	61 MIN.	61 MIN.
OPERATING CAPACITY		
RACKS PER HOUR (NSF rated)	60	60
WASH TANK CAPACITY	8 GAL.	(30.3 L)
PUMP CAPACITY	68 GPM	(257 LPM)
WATER REQUIREMENTS		
WITHOUT BOOSTER HEATER	180°F	(82°C)
WITH BOOSTER HEATER	140°F	(60°C)
WATER INLET	¾"	1.9cm
DRAIN CONNECTION	2"	5.1cm
RINSE PRESSURE SET	20 PSI	1.41 kg/cm ²
CYCLE TEMPERATURES		
WASH-°F	155°F-160°F	(68°C/71°C)
RINSE-°F	180°F-195°F	(82°C/90°C)
DIMENSIONS		
DEPTH	25"	(63.5cm)
WIDTH	25 ½"	(65cm)
HEIGHT	59-60	(150-152cm)
STANDARD TABLE HEIGHT	34"	(86.3cm)
MAX CLEARANCE FOR DISHES	17 ½"	
DRAIN CONNECTION (OFF FLOOR)	11 ½" – 12 ½"	(29-32cm)

1.1. CMA-180/CMA-180T

ELECTRICAL RATING	VOLTS	PHASE	AMPS
WITHOUT BOOSTER	208	1	28/35
	240	1	30/38
	208	3	20/24
	240	3	21/26
<hr/>			
ELECTRICAL RATING	208	1	71/78
	240	1	80/88
	208	3	45/49
	240	3	50/55
<hr/>			
SHIPPING WEIGHT			
WITHOUT BOOSTER			332#
WITH BOOSTER			375#



2. Getting Started

2.1. Introduction to CMA-180

The CMA-180 is a hot water sanitizing, single rack, door-type dishmachine. It is a stand-alone machine featuring a self-contained booster heater (optional). The only external connections necessary are power supply, water supply, drainpipe, and chemical dispensers. The machine utilizes recirculated wash water and fresh water final rinse. The CMA-180 can be converted both as a straight through and corner with a door handle kit.

Operation of the CMA-180 is automatic. When the door is opened and then closed, the wash cycle begins automatically. To initially fill the machine daily, open the hand operated fill valve on the top of the machine. The machine is full when water begins to flow into the scrap trap. The wash tank heater will maintain the wash water temperature at 155°F. The booster heater will produce a minimum of 180°F final rinse water each cycle.

This manual is structured to provide a complete reference guide to the CMA-180. It is presented in a manner that all users will be able to comprehend and use as an effective tool in supporting the operation and maintenance of the dishmachine. The first section explains how the machine is packaged and what to look for when receiving the machine.

Instructions are provided in the manual explaining how to unpack the machine and then install and set up the machine for use. Requirements are given for plumbing, wiring, and space considerations. *These attributes of the machine are always taken into consideration by our well-trained sales representatives prior to the order being placed.* In the manual, additional installation guidance is given to ensure the machine can run at optimum conditions.

The Operation Section of the manual may be used for instruction and procedures when required. We make this portion of the manual easy to understand so that all levels of operators may be able to read and comprehend the operation of the machine. The function of the machine itself is mostly automatic and takes little training to put into full operation. The Operation Section also includes diagnostic considerations for the machine when problems occur.

We are committed to providing the best machines and customer service in the food industry and your feedback is welcome.

CMA warrants the workmanship of the machine.

2.2. Receiving and Installation

Step 1: Remove packaging material.

Step 2: Remove service manual and machine legs from inside the wash tank.

Step 3: Install legs into dishmachine leg lockets and adjust the feet. Set the machine in place. Level the machine side – to – side and front – to – back.

Step 4: It is recommended that a distance of at least eight inches (8”) be between the table scrap sink and the dishmachine.

2.2.1. Electrical*

The control panel provides a 1” conduit connection point on the rear of the panel. Refer to Section 3 for wiring options.

This machine is equipped to handle both single and three phase applications. See Section 1: Specifications 1.1 for the proper electrical ratings.

2.2.2. Plumbing*

Minimum 140°F / Minimum 180°F (if machine ordered without booster heater, water supply ¾” – minimum 20 psi, 6 gpm flow rate and 60 gph recovery rate. Plumbing connection located on the top of the machine.

The drain is a two inch (2”) pipe sleeve attached by “No-Hub” plumbing connection at the bottom of the scrap trap. Account’s drain should be no higher than 11” to allow the machine to drain properly.

2.2.3. Nova Detergent and Rinse Dispenser

The NOVA Detergent and Rinse Dispenser has its own reference manual. Familiarize yourself with the dispenser’s reference manual before proceeding with installation.

1. The NOVA dispenser is pre-wired with a multi-conductor electrical cable that is to be run through a conduit to the power block inside the control panel drawer. Use a ½” watertight conduit meeting all local and national codes. A conduit fitting is present on the bottom of the dispenser where the power cable exits. Use the same conduit fitting in the back of the control box. The probe is also pre-wired (see two violet wires routed from the control box to the probe location inside the wash tank heater thermostat enclosure).
 - i. Run an appropriate length of ½” conduit from your dispenser to the control box where it will be secured. The conduit needs to be of sufficient length and

* Electrical and plumbing connections must be made by qualified person who comply with all available Federal, State, and Local Health, Electrical, Plumbing and Safety codes

flexibility to permit the machine to be moved for cleaning without having to disconnect any wiring.

- ii. Run your dispenser wires through the conduit to the control box.
- iii. Run your probe wires to the control box.
- iv. With the machine's power "OFF", connect your detergent and rinse dispenser wires to the red and blue terminals of the power block supplied inside the control box. The table that follows lists the function of each conductor of the multi-conductor electrical cable.

Wire Colors	Circuit Voltage	Function
Gray/Violet	200 VAC-249 VAC 50/60 Hz	Main AC Power
Brown	200 VAC-249 VAC 50/60 Hz	Main AC Power
Black	No Connection. Insulate this wire!	This wire is LIVE!
Yellow	24 VAC-240 VAC 50/60 Hz	Detergent Signal
White/Yellow	24 VAC-240 VAC 50/60 Hz	Detergent Signal
Violet	24 VAC-240 VAC 50/60 Hz	Rinse Signal
White/Violet	24 VAC-240 VAC 50/60 Hz	Rinse Signal

The individual conductors need to be connected as shown on the wire diagram below. Probe wires are to be striped, crimped on barrel male and female connectors provided, and connected to the pre-wired violet wires in the control box.

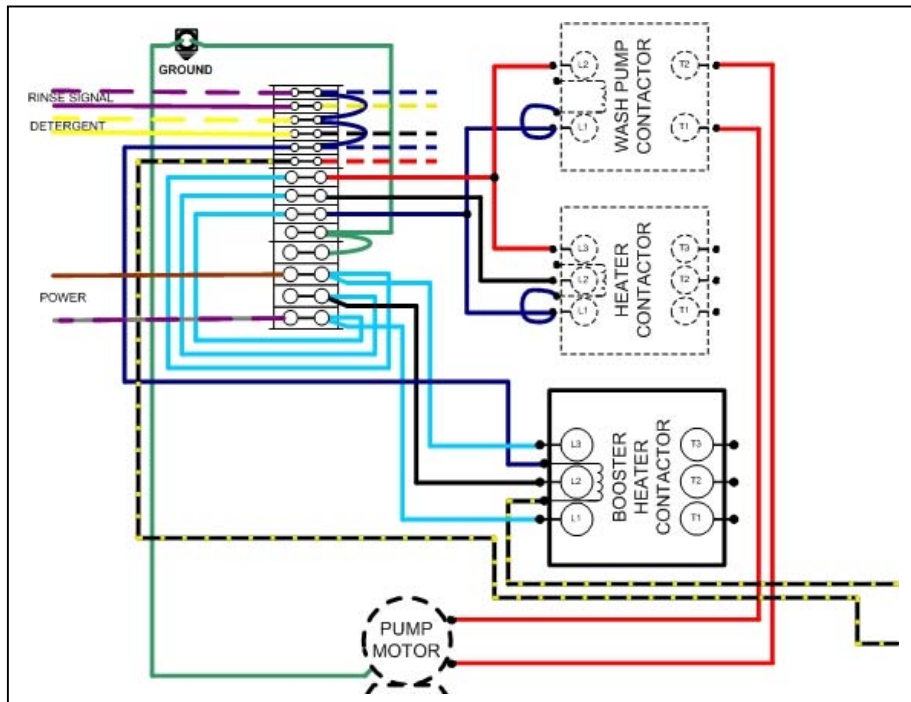

2. Remove the plug from the mixing chamber located by the vacuum breaker on the back of machine; and install the rinse injection fitting (supplied with your dispenser).
3. A 7/8" detergent injection hole is provided in the back of the wash tank. Remove the S.S. plug and install the detergent fitting (supplied with your dispenser).
4. A 7/8" chemical probe hole is provided in the front of the wash tank heater just below hi limit switch. Insert the probe into the hole from inside the wash tank and secure it with the probe retaining nut provided. Connect ring connectors to the probe with nuts and star washers provided.
5. The final step of installing the CMA supplied Detergent and Rinse Dispenser is programming it to your specific application. The reference manual supplied with the dispenser shows you how to program it.
 - Keep in mind while reading the reference manual that the CMA-180 operates in "probe" mode. (This mode is selected by setting a value of "1" in screen 21).
 - Screen 22 must be set to "1" (Door).

There are four user functions with this dispenser. Their operation is described in the reference manual.

2.2.4. Exhaust Fan Control

2/28/05

CMA-180 EXHAUST FAN TIMER CONTROL

THE FOLLOWING CONNECTIONS HAVE BEEN MADE:

#1 and #3 quick connect terminals have been connected with red and blue wires to the terminal L1 and L3 on the heater contactor.

#2 and #3 quick connect terminals have been connected with red/black and blue wires to the fan control contactor coil.

#6 and #3 quick connect terminals have been connected with blue wires to #5 micro switch terminals.

Power source of 220 vac or 110 vac (depending on fan motor data) have been connected to L1 and L2 (N).

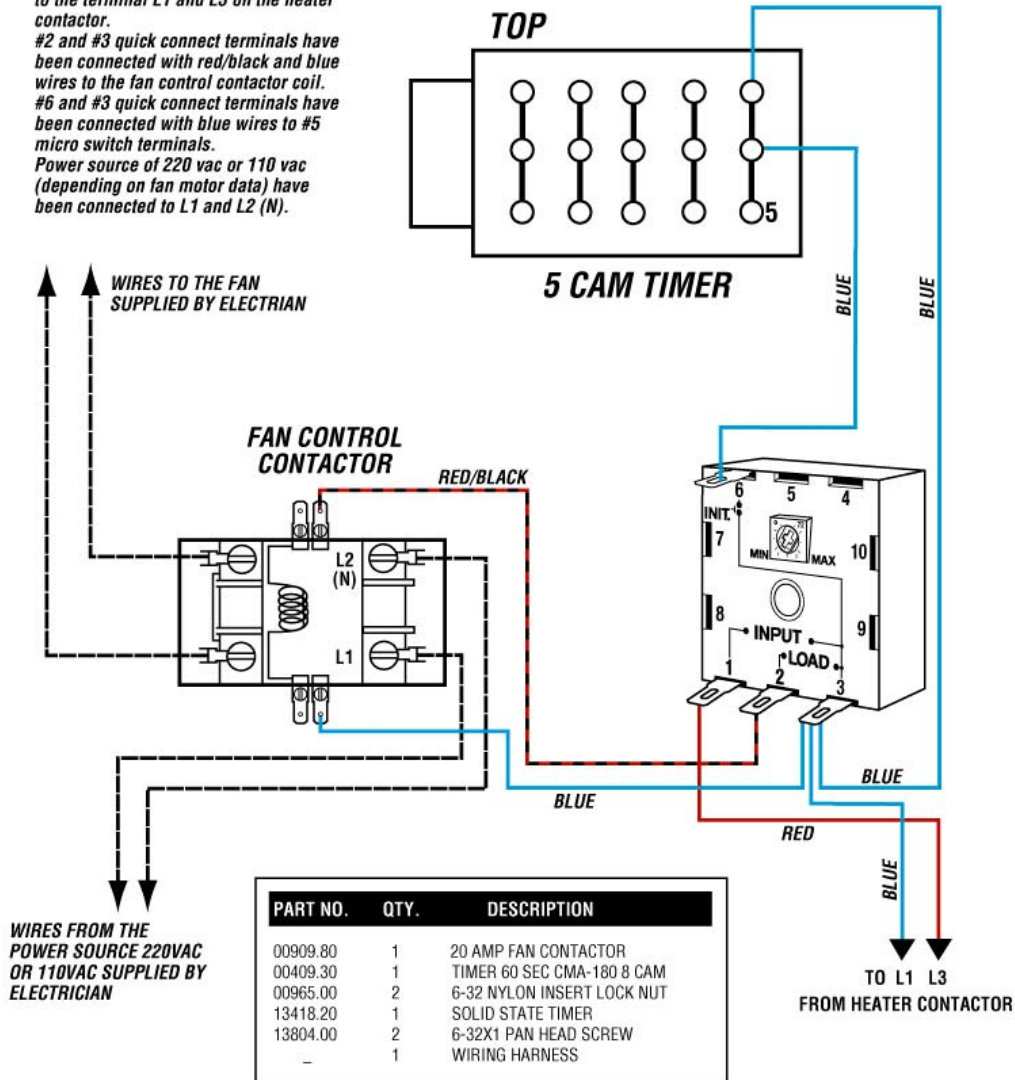

2.2.5. Water Tempering Kit

180/44/66 Water Tempering Valve Kit
P/N 13470.00

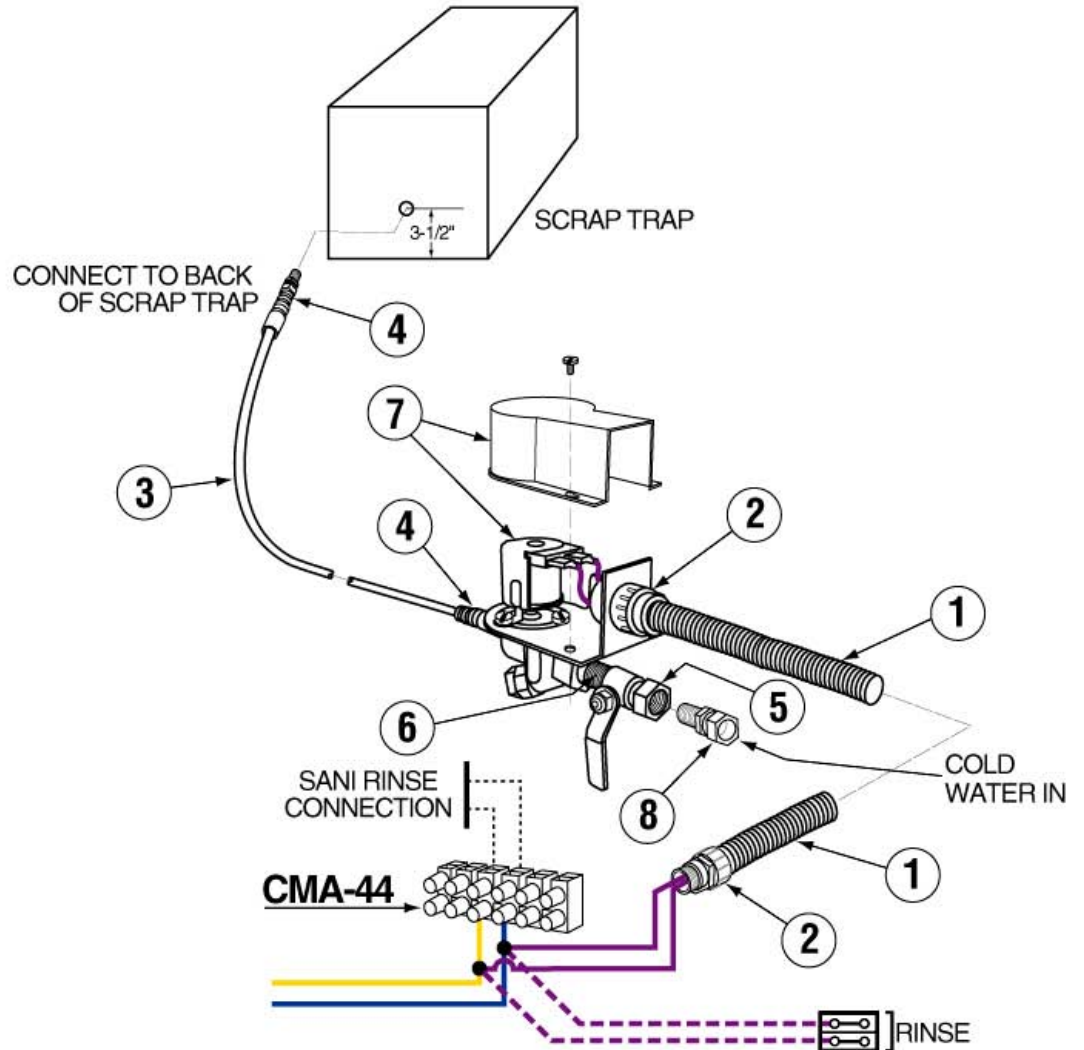

ITEM NO.	P/N	NO REQ'D	DESCRIPTION
1.	00400.00	2	CONDUIT 3/8" SEALTITE
2.	00401.00	2	ST-3/8" STRAIGHT CONNECTOR
3.	00425.54	6	CHEMICAL TUBING WHITE
4.	03415.50	2	FLEX-TIGHT FITTING
5.	41010.00	1	1/4" MIP BALL VALVE
6.	41011.00	1	NIPPLE BRASS 1/4" CLOSE
7.	41015.05	1	SOLENOID VALVE 1/4" W/COVER 220V
8.	40116.00	1	1/4" COMP X 1/4" MIPFTG

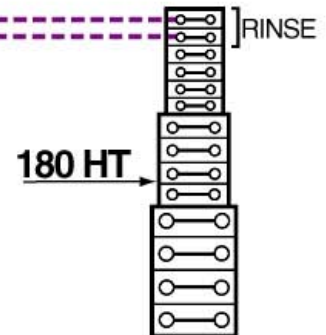

2.2.6. Installation Checklist

- Dishmachine checked for concealed damage.
- Hot water supply is 140° (60°C)
- Incoming water supply line is ¾".
- Incoming water supply is 6 gpm minimum capable at 20 psi flow pressure.
- Machine circuit breaker is properly sized.
- Service voltage and phase type are correct to machine data plate.
- High leg of voltage is connected to L2 (three-phase).
- Dishmachine is properly ventilated.
- Floor drain plumbing is installed with air gap.
- Dishmachine is properly grounded.
- Dishmachine is properly leveled.
- Dishrack guides are adjusted to level of dishtable.
- Machine circuit breaker is labeled D/W

2.2.7. Machine Start-Up Procedures

1. Open doors and install the overflow & scrap trap on the right side of the machine.
2. Place the scrap baskets over the wash tanks.
3. Secure the wash & rinse arms and check the free-spin.
4. Open the control cover and select 'normal' toggle switch position.
5. Adjust the rinse pressure to 20 psi flow pressure using the regulator and the gauge.
 - a. Turn the power switch to the "Off" position.
 - b. Close doors and open the hand-operated fill valve until the water overflows into the scrap trap.
 - c. Turn the power switch to "on" position.
 - d. While holding "flush" toggle switch, to activate the water solenoid, adjust the pressure regulator until the gauge reads 20 psi.
6. Connect the detergent and rinse dispenser to the power block supplied & labeled inside the control box (208-220) volt).
7. Remove the plug from the mixing chamber and install the rinse injection fitting.
8. A 7/8" chemical probe hole is provided in the wash tank.
9. A 7/8" detergent fitting hole is provided in the wash tank.
10. Check the machine operating temperatures. Adjust if necessary.
 - a. After the machine has warmed up for five to ten minutes (5 – 10 min.), observe the wash and rinse temperatures. The wash temperature must be 155°F minimum. The rinse temperature must be 180°F minimum. If necessary, adjust the temperatures by removing the panel in front of the respective heater and turning the adjustment post clockwise to increase.

NOTE: Rinse water temperature must be observed during the rinse cycle.

11. Check all water and drain fittings for leaks.
12. Install the wall chart and instruct the machine operator on the proper cleaning and operation of the CMA-180.

2.2.8. Electrical Requirements

The CMA-180 comes standard factory, wired for 3-phase operation. Check the electrical data plate to confirm this. If the account requires 1 phase, refer to "Electrical Requirements", Section 1-A, for proper wiring instruction for conversion. Also check the wiring diagram to properly wire the terminal power block, tank heater, and booster heater for 1 phase (or 1B diagram below).

SINGLE PHASE POWER

NOTE: 80 amp service is required when CMA-180 is wired for single-phase with the booster heater. See "Electrical Requirements" section for **DUAL** 1-phase power supply. Circuit breaker requirement (1) 50 amp & 30 amp.

Figure 1-B

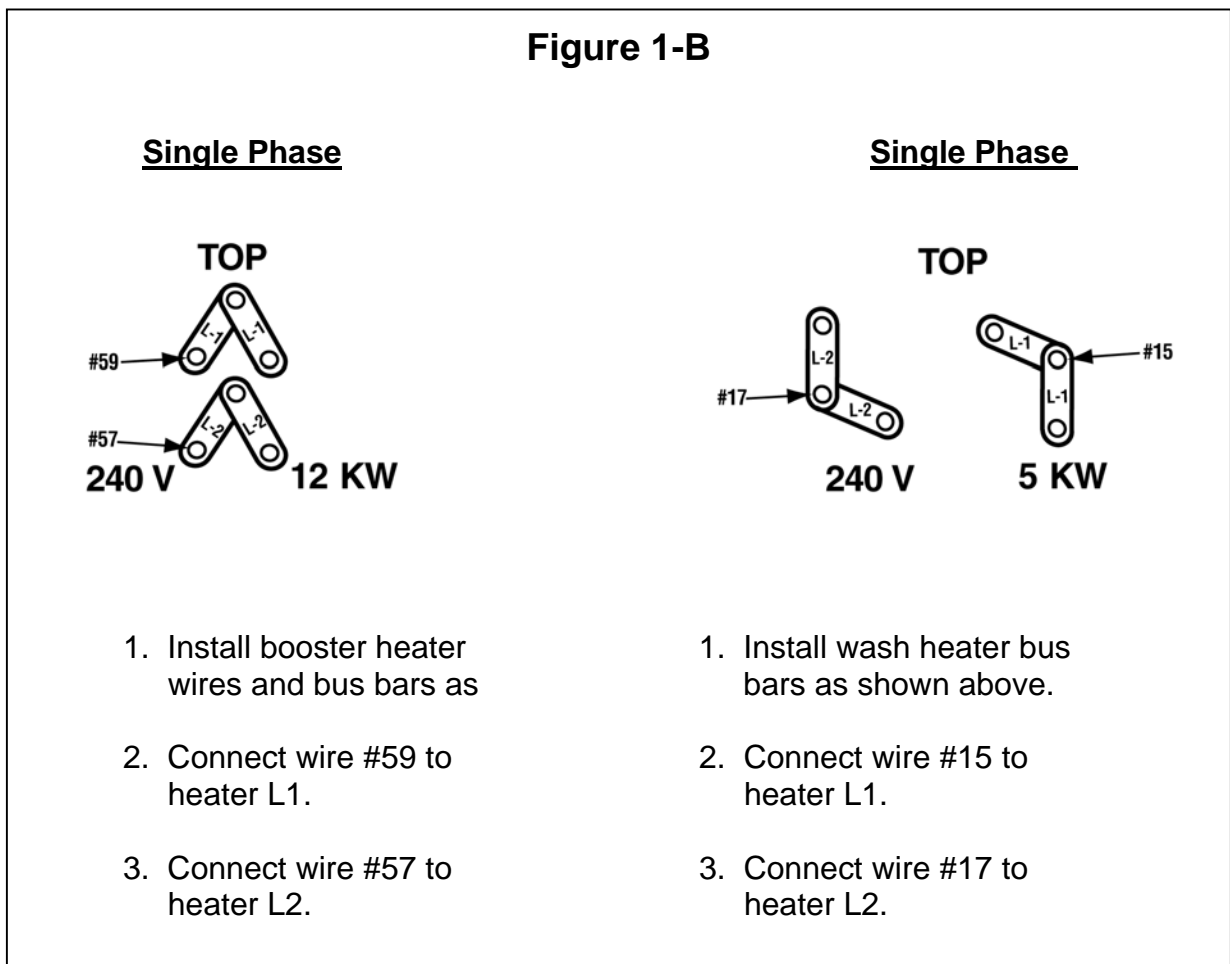

3. Wiring Options

3-Phase and 1 Phase Wiring Options

Single-Source
220V 3-Phase
(20 amp/12 g*)

Single-Source
220V 3-Phase
(50 amp/8 g*)

Single-Source
220V 1-Phase
(80 amp/4 g*)

Two-Source
220V 1-Phase
(50 amp/8 g*)
(30 amp/10 g*)

Single-Source
220V 1-Phase
(30 amp/10 G*)

(without Booster)

(without booster)

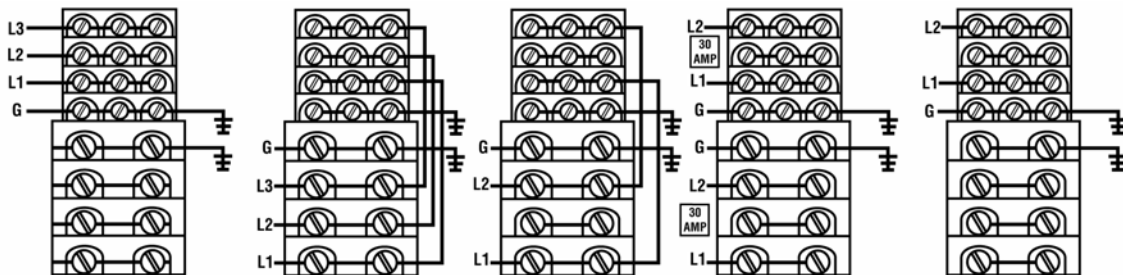

*g=gauge

DISPENSER HOOK-UP

1. The power signal is 208/230 volts. The power block is labeled inside the control box. Conduit holes for both detergent & rinse are supplied on the control box.
2. A threaded (1/8") injection point is provided on the final rinse Teflon mixing chamber located off the back of the machine.
3. A (7/8") hole is provided in the tank for a probe access. It is located on the front side of the wash tank inside the heater cover.

MAIN POWER CONNECTION

Please refer to the machine data plate or choose one of the five (5) power connections illustrated above (1A). Electrical requirements are shown for machines with or without booster heater, three or single phase.

WARNING: Insure that the machine is properly grounded and complies to all local and national codes. Injury or death may occur from shock, if the machine is not properly grounded.

Install power supply wires, L1, L2 and L3 (3-Phase) to the appropriate terminals marked L1, L2, and L3 on the power block. (If applicable, the high or "wild" leg must be connected to the L2 Terminal.)

4. Quick service guide

MODEL: CMA 180 HIGH TEMP

TECHNICAL ISSUE	CAUSE	SOLUTION
Door magnetic reed switch problem	Faulty magnetic reed switch	Check wire connections inside control box Contact factory for new retrofit, corner P/N 00566.10 straight P/N 00566.20
	Door mechanical switch problem	Switch alignment issue Switch button broke
Pump motor not running	Delimer switch is in <i>OFF</i> position	Flip to <i>NORMAL</i> position
	Loose wire connections	Check and crimp connectors
	Faulty # 3 micro switch in cam timer	Replace micro switch, P/N 00411.00
	Faulty contactor	Replace contactor, P/N 00404.85
	Faulty wash pump motor	Replace wash pump motor, P/N 00201.00
Pump motor runs continuous	Faulty # 3 micro switch in cam timer	Replace micro switch, P/N 00411.00
	Delimer switch is in <i>DELIME</i> position	Flip to <i>NORMAL</i> position
	Faulty contactor	Replace contactor, P/N 00404.85
Final rinse water below 180 degree F	Booster heater thermostat not properly set	Adjust thermostat
	Incoming main water temperature below 140 F	Raise water temperature to 140 F
	Tripped or faulty high limit switch	Reset or replace high limit switch, P/N 17523.51
	Faulty contactor	Replace contactor, P/N 13003.17
	Faulty booster heater element	Replace heating element, P/N 13417.67
	Scaled heating element	De- scale heating element
Wash tank heater is not operational	Thermostat is not properly adjusted	Adjust thermostat
	Loose lead connection	Check connectors and secure
	Tripped or faulty high limit switch	Reset or replace high limit switch, P/N 17523.51
	Faulty float switch	Replace float switch, P/N 13463.00
	Faulty contactor	Replace contactor, P/N13003.50
	Faulty heating element	Replace heating element, P/N 13417.65
Low water pressure at the final rinse	Water regulator not adjusted properly	Adjust regulator to 18-20 PSI
	Clogged final rinse spray jets	Clean jets
	Missing final rinse spray end cap	Replace end cap, P/N 00308.17
	Low incoming water pressure from building	Increase pressure
Water solenoid leaks	Scaled or dirty solenoid valve	Clean valve
	Faulty solenoid valve diaphragm	Replace diaphragm, P/N 00706.00
Wash water temperature too low/high	Thermostat not properly set	Adjust thermostat
	Scaled heating element	Clean scale, delime machine
	Faulty temperature gauge	Replace gauge, P/N 03202.00
Machine does not operate when the door is closed	Position or proper operation of door switch	Adjust or replace door switch, P/N 00557.55
	Delimer switch is on <i>OFF</i> position	Flip to <i>NORMAL</i> position
	Faulty 1st micro switch in cam timer	Replace micro switch, P/N 00411.00
	Check cam timer motor	Replace timer if needed, P/N 00409.17
	Check ice cube relay	Replace if faulty, P/N 00631.05
Faulty wash pump contactor	Replace contactor, P/N 00404.85	

5. INITIAL PARTS KIT P/N 1100.17

P/N	DESCRIPTION	NO. REQ'D
00121.18	CMA-180 Drain Stopper O Ring	1
00200.10	Pump Assy 110/220V 60 Hz (Open)	1
00206.00	Pump Seal Kit	1
00302.19	CMA-180 Buna Gasket (#302.17)	1
00304.17	CMA-180 Wash Spray Arm	1
00304.19	CMA-180 Rinse Arm W/Bearing	1
00308.17	CMA-180 Rinse Arm SS End Plug	1
00308.50	Spray Arm End Plug SS	1
00363.00	Spray Base Lock Pin	1
00404.85	Contactora 208.240V 20AMP	1
00405.00	Start/Fill Switch Toggle	1
00411.00	Micro Switch	1
00475.00	Toggle Switch DPDT 15 AMP/Delimer	1
00501.17	Timer Motor Assy 60 Sec. 220V/60Hz	1
00562.00	Roller Door Switch	1
00602.00	Door Spring	1
00631.05	Ice Cube Relay 220V	1
00706.00	¾ Water Solenoid Repair Kit JE	1
00735.00	¾ Vac Breaker Rep Kit Watts	1
00738.15	¾ Solenoid Coil JE 220V	1
03202.00	Thermometer CMA-180 "Wash"	1
03202.00	Thermometer CMA-180 "Rinse"	1
03408.55	Counter (Face Mount Sm) 220/50	1
13003.17	Contactora 60 AMP 3 Pole	1
13003.50	Contactora 30 AMP	1
13304.55	SS Final Rinse Spray Jet – HT	1
13415.00	EGO Thermostat Retrofit Kit Rinse	1
13417.47	CMA-180 Booster Heater Gasket	1
13417.65	Immersion Heater 5 Kw 3hp/1ph	1
13417.67	Immersion Heater 12 Kw 3PH/1PH	1
13417.85	Thermostat Heater CMA-44/CMA-180 Wash	1
13463.10	Liquid Level Switch SS – CMA-44	1
13605.00	Pressure Gauge	1
00421.90	CMA-180 Power Switch	1
00421.78	CMA-180 Illuminated Plug	1
17523.51	Hi Limit Switch 250 deg	1

NOTE: CMA recommend that this Model CMA-180 initial parts kit be kept on hand, as a back up supply, in the event your machine should require emergency service. All the parts included in this kit are unique to the CMA-180 dishmachine, and are essential to the "quality" operation and customer service to the CMA-180 unit.

6. Auto-Fill Solid State Timer

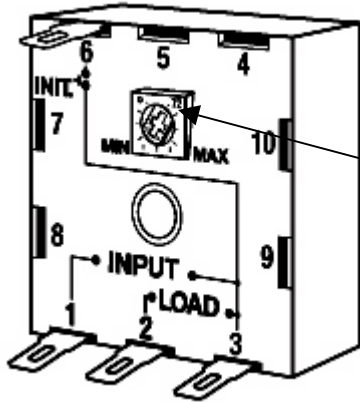

Pre-selected delay period can be adjusted by turning securely small flat screwdriver. Since the range of this solid state timer is from 6 seconds to 240 seconds, you should adjust delay by small increment.

Removal of input power will reset the control.

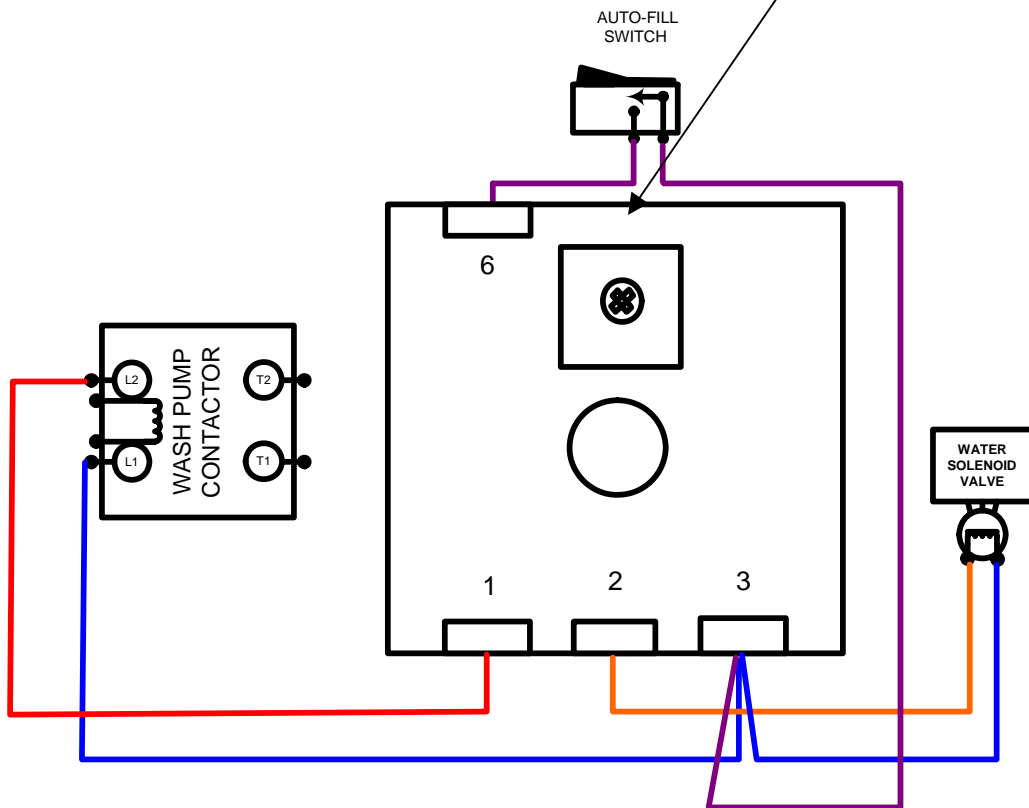

8. Wire Diagram for CMA-180 Booster Only

