

CMA OPTIONAL DISHMACHINE ACCESSORIES

Temp Sure Booster Heater

1. For Models AH, B, C, EST-AH, EST-C, E, L-1X, L-1X16 and GL-X
Designed for Low Temp machines to provide a 40° temperature rise.

Stand-Alone Temp-Sure



Hatco Booster Heater

2. A Free-Standing Booster Heater for Conveyors
Model C-45 = 70° Rise Electric (gas slightly more)
Model C-24 = 40° Rise Electric (gas slightly more)

HATCO Booster Heater



Dishtables

3. Four (4) different sizes, 26", 36", 48" and 60", plus custom. Stainless Steel legs included. Custom Tables available upon request.

Clean Table – Left



Soiled Table – Right



Work Stations for Undercounter Models

4. For models L-1X, L-1X16, UC50e, UC65e and 180UC

Undercounter Table with Optional Pre-Rinse



Fisher Pre-Rinse Assembly

5. Two (2) models available: Wall Mount and Single Deck Mount
Available for Soiled Tables & Three-Compartment Sinks

Wall Mount

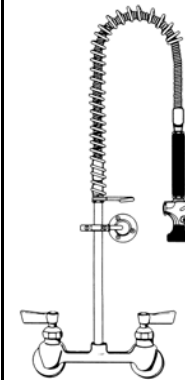

Single Deck Mount

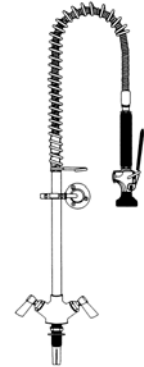

Sani-Alarm – Chemical Alert System

6. Available for all low-temp chemical sanitizing dishmachines, both door and undercounter. It has an audible alarm when the dishmachine dispenser runs out of product (the alarm automatically will let the operator know).

Sani-Alarm

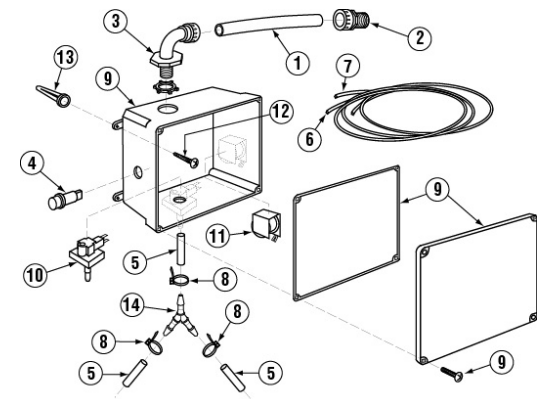

Chemical Dispenser

7. For models CMA-180 and 180-UC

A Dual (2-product) built-in dispenser system for detergent and rinse-aid.

**Detergent and Rinse Dispenser
(shown installed)**



Vent Hoods – For Steam Control

8.

For models EST-44 and EST-66 Conveyors

Vent Hoods / Cowls



21" Corner Feed Table – Designed for Purpose

9. For models EST-44 and EST-66 Conveyors

Automatically feeds dish racks into the Conveyor Dishwasher.

Corner Feed Table



48" Overhead Slant Shelf

10.

Provides wall mount storage for two (2) dish racks.

Slant Shelf



Universal Pedestal –

- 11. Provides storage for two empty dishracks beneath the machine. The pedestal has been designed to mount to CMA undercounter Models L-1X, L-1X16, 180-UC, UC50e and UC65e.

Universal Pedestal

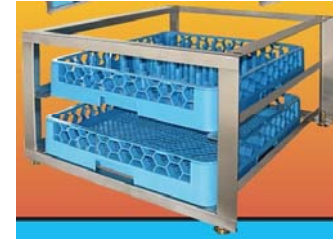

Taller Option Scullery – Models CMA-180, AH, and C (Corners and Straights)
 Provides for an additional 10” opening door clearance, for cleaning sheet pans and other larger items.

- 12. **Taller Option Conveyor– Models EST-44 and EST-66**
 Provides for an additional 6” opening door clearance, for cleaning sheet pans and other larger items.

Taller Option – Models EST and E (Corners and Straights)
 Provides for an additional 3-1/2” opening door clearance (normally 17” to a larger 20-1/2”, for cleaning extra large pizza pans and other large utensils.

Taller Models Available



Water Tempering Kit –

- 13. Available for all High-Temp models, to lower wastewater temperature to meet Regulatory Requirements, for some States (which is 139°).

Water Tempering Kit

